



Operating Guide

VLT[®] Midi Drive FC 280



Contents

1 Introduction	4
1.1 Purpose of the Manual	4
1.2 Additional Resources	4
1.3 Document and Software Version	4
1.4 Product Overview	4
1.5 Approvals and Certifications	5
1.6 Disposal	6
2 Safety	7
2.1 Safety Symbols	7
2.2 Qualified Personnel	7
2.3 Safety Precautions	7
3 Mechanical Installation	9
3.1 Unpacking	9
3.2 Installation Environment	10
3.3 Mounting	10
4 Electrical Installation	12
4.1 Safety Instructions	12
4.2 EMC-compliant Installation	12
4.3 Grounding	12
4.4 Wiring Schematic	14
4.5 Access	16
4.6 Motor Connection	16
4.7 AC Mains Connection	17
4.8 Control Wiring	18
4.8.1 Control Terminal Types	18
4.8.2 Wiring to Control Terminals	19
4.8.3 Enabling Motor Operation (Terminal 27)	19
4.8.4 Mechanical Brake Control	19
4.8.5 USB Data Communication	20
4.9 Installation Checklist	21
5 Commissioning	22
5.1 Safety Instructions	22
5.2 Applying Power	22
5.3 Local Control Panel Operation	22
5.3.1 Numeric Local Control Panel (LCP)	22
5.3.2 The Right-key Function on NLCP	24

5.3.3 Quick Menu on NLCP	24
5.3.4 Main Menu on NLCP	26
5.3.5 GLCP Layout	28
5.3.6 Parameter Settings	29
5.3.7 Changing Parameter Settings with GLCP	29
5.3.8 Uploading/Downloading Data to/from the GLCP	29
5.3.9 Restoring Default Settings with LCP	29
5.4 Basic Programming	30
5.4.1 Asynchronous Motor Set-up	30
5.4.2 PM Motor Set-up in VVC ⁺	30
5.4.3 Automatic Motor Adaptation (AMA)	31
5.5 Checking Motor Rotation	32
5.6 Checking Encoder Rotation	32
5.7 Local-control Test	33
5.8 System Start-up	33
5.9 STO Commissioning	33
6 Safe Torque Off (STO)	34
6.1 Safety Precautions for STO	35
6.2 Safe Torque Off Installation	35
6.3 STO Commissioning	36
6.3.1 Activation of Safe Torque Off	36
6.3.2 Deactivation of Safe Torque Off	36
6.3.3 STO Commissioning Test	36
6.3.4 Test for STO Applications in Manual Restart Mode	37
6.3.5 Test for STO Applications in Automatic Restart Mode	37
6.4 Maintenance and Service for STO	37
6.5 STO Technical Data	38
7 Application Examples	39
7.1 Introduction	39
7.2 Application Examples	39
7.2.1 AMA	39
7.2.2 Speed	39
7.2.3 Start/Stop	40
7.2.4 External Alarm Reset	41
7.2.5 Motor Thermistor	41
7.2.6 SLC	41
8 Maintenance, Diagnostics, and Troubleshooting	42
8.1 Maintenance and Service	42

8.2 Warning and Alarm Types	42
8.3 Warning and Alarm Display	42
8.4 List of Warnings and Alarms	44
8.4.1 Warning and Alarm Code List	44
8.5 Troubleshooting	48
9 Specifications	50
9.1 Electrical Data	50
9.2 Mains Supply	52
9.3 Motor Output and Motor Data	52
9.4 Ambient Conditions	52
9.5 Cable Specifications	53
9.6 Control Input/Output and Control Data	53
9.7 Connection Tightening Torques	56
9.8 Fuses and Circuit Breakers	56
9.9 Enclosure Sizes, Power Ratings, and Dimensions	58
10 Appendix	61
10.1 Symbols, Abbreviations, and Conventions	61
10.2 Parameter Menu Structure	61
Index	65

1 Introduction

1.1 Purpose of the Manual

This operating guide provides information for safe installation and commissioning of the VLT® Midi Drive FC 280 frequency converter.

The operating guide is intended for use by qualified personnel.

To use the frequency converter safely and professionally, read and follow the operating guide. Pay particular attention to the safety instructions and general warnings. Always keep this operating guide with the frequency converter.

VLT® is a registered trademark.

1.2 Additional Resources

Resources available to understand advanced frequency converter functions, programming, and maintenance:

- *VLT® Midi Drive FC 280 Design Guide*, provides detailed information about the design and applications of the frequency converter.
- *VLT® Midi Drive FC 280 Programming Guide*, provides information on how to program and includes complete parameter descriptions.

Supplementary publications and manuals are available from Danfoss. See drives.danfoss.com/knowledge-center/technical-documentation/ for listings.

1.3 Document and Software Version

This manual is regularly reviewed and updated. All suggestions for improvement are welcome. *Table 1.1* shows the document version and the corresponding software version.

Edition	Remarks	Software version
MG07A3	More information for single-phase and 3-phase 200–240 V frequency converters introduced.	1.2

Table 1.1 Document and Software Version

1.4 Product Overview

1.4.1 Intended Use

The frequency converter is an electronic motor controller intended for:

- Regulation of motor speed in response to system feedback or to remote commands from external controllers. A power drive system consists of the frequency converter, the motor, and equipment driven by the motor.
- System and motor status surveillance.

The frequency converter can also be used for motor overload protection.

Depending on configuration, the frequency converter can be used in standalone applications or form part of a larger appliance or installation.

The frequency converter is allowed for use in residential, industrial, and commercial environments in accordance with local laws and standards.

NOTICE

In a residential environment, this product can cause radio interference, in which case supplementary mitigation measures may be required.

Foreseeable misuse

Do not use the frequency converter in applications which are non-compliant with specified operating conditions and environments. Ensure compliance with the conditions specified in *chapter 9 Specifications*.

1.4.2 Block Diagram of the Frequency Converter

Illustration 1.1 is a block diagram of the internal components of the frequency converter.

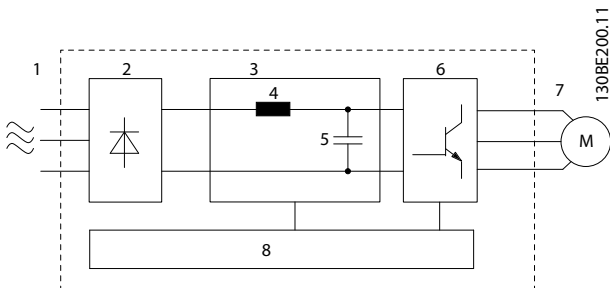

Area	Component	Functions
8	Control circuitry	<ul style="list-style-type: none"> Input power, internal processing, output, and motor current are monitored to provide efficient operation and control. User interface and external commands are monitored and performed. Status output and control can be provided.

Illustration 1.1 Example of Block Diagram for a Frequency Converter

Area	Component	Functions
1	Mains input	<ul style="list-style-type: none"> AC mains supply to the frequency converter.
2	Rectifier	<ul style="list-style-type: none"> The rectifier bridge converts the AC input to DC current to supply inverter power.
3	DC bus	<ul style="list-style-type: none"> Intermediate DC-bus circuit handles the DC current.
4	DC reactor	<ul style="list-style-type: none"> Filters the intermediate DC circuit current. Provides mains transient protection. Reduces the root mean square (RMS) current. Raises the power factor reflected back to the line. Reduces harmonics on the AC input.
5	Capacitor bank	<ul style="list-style-type: none"> Stores the DC power. Provides ride-through protection for short power losses.
6	Inverter	<ul style="list-style-type: none"> Converts the DC into a controlled PWM AC waveform for a controlled variable output to the motor.
7	Output to motor	<ul style="list-style-type: none"> Regulated 3-phase output power to the motor.

1.4.3 Enclosure Sizes and Power Ratings

For enclosure sizes and power ratings of the frequency converters, refer to *chapter 9.9 Enclosure Sizes, Power Ratings, and Dimensions*.

1.4.4 Safe Torque Off (STO)

The VLT® Midi Drive FC 280 frequency converter supports Safe Torque Off (STO). See *chapter 6 Safe Torque Off (STO)* for details about the installation, commissioning, maintenance, and technical data of STO.

1.5 Approvals and Certifications

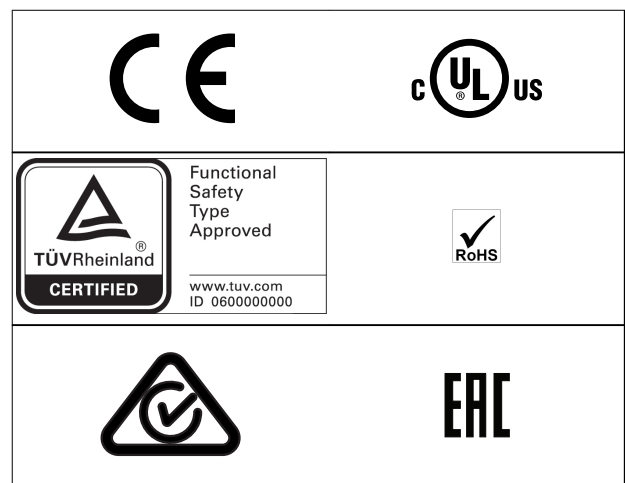

For compliance with the European Agreement concerning International Carriage of Dangerous Goods by Inland Waterways (ADN), refer to *chapter ADN-compliant Installation* in the *VLT® Midi Drive FC 280 Design Guide*.

The frequency converter complies with UL 508C thermal memory retention requirements. For more information, refer to *chapter Motor Thermal Protection* in the *VLT® Midi Drive FC 280 Design Guide*.

Applied standards and compliance for STO

Using STO on terminals 37 and 38 requires fulfillment of all provisions for safety including relevant laws, regulations, and guidelines. The integrated STO function complies with the following standards:

- IEC/EN 61508: 2010 SIL2
- IEC/EN 61800-5-2: 2007 SIL2
- IEC/EN 62061: 2012 SILCL of SIL2
- IEC/EN 61326-3-1: 2008
- EN ISO 13849-1: 2008 Category 3 PL d

1.6 Disposal

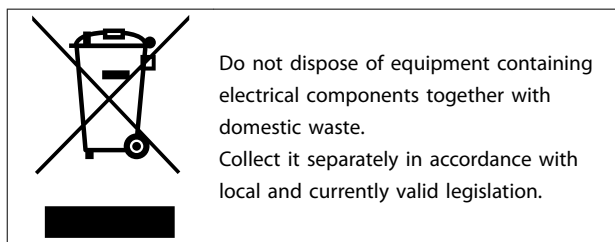

2 Safety

2.1 Safety Symbols

The following symbols are used in this document:

⚠ WARNING

Indicates a potentially hazardous situation that could result in death or serious injury.

⚠ CAUTION

Indicates a potentially hazardous situation that could result in minor or moderate injury. It can also be used to alert against unsafe practices.

NOTICE

Indicates important information, including situations that can result in damage to equipment or property.

2.2 Qualified Personnel

Correct and reliable transport, storage, installation, operation, and maintenance are required for the trouble-free and safe operation of the frequency converter. Only qualified personnel are allowed to install or operate this equipment.

Qualified personnel are defined as trained staff, who are authorized to install, commission, and maintain equipment, systems, and circuits in accordance with pertinent laws and regulations. Also, the personnel must be familiar with the instructions and safety measures described in this guide.

2.3 Safety Precautions

⚠ WARNING

HIGH VOLTAGE

Frequency converters contain high voltage when connected to AC mains input, DC supply, or load sharing. Failure to perform installation, start-up, and maintenance by qualified personnel can result in death or serious injury.

- Only qualified personnel must perform installation, start-up, and maintenance.

⚠ WARNING

UNINTENDED START

When the frequency converter is connected to AC mains, DC supply, or load sharing, the motor may start at any time. Unintended start during programming, service, or repair work can result in death, serious injury, or property damage. The motor can start with an external switch, a fieldbus command, an input reference signal from the LCP, via remote operation using MCT 10 Set-up Software, or after a cleared fault condition.

To prevent unintended motor start:

- Disconnect the frequency converter from the mains.
- Press [Off/Reset] on the LCP before programming parameters.
- Completely wire and assemble the frequency converter, motor, and any driven equipment before connecting the frequency converter to AC mains, DC supply, or load sharing.

⚠ WARNING

DISCHARGE TIME

The frequency converter contains DC-link capacitors, which can remain charged even when the frequency converter is not powered. High voltage can be present even when the warning LED indicator lights are off. Failure to wait the specified time after power has been removed before performing service or repair work can result in death or serious injury.

- Stop the motor.
- Disconnect AC mains and remote DC-link supplies, including battery back-ups, UPS, and DC-link connections to other frequency converters.
- Disconnect or lock PM motor.
- Wait for the capacitors to discharge fully. The minimum waiting time is specified in *Table 2.1*.
- Before performing any service or repair work, use an appropriate voltage measuring device to make sure that the capacitors are fully discharged.

Voltage [V]	Power range [kW (hp)]	Minimum waiting time (minutes)
200–240	0.37–3.7 (0.5–5)	4
380–480	0.37–7.5 (0.5–10)	4
	11–22 (15–30)	15

Table 2.1 Discharge Time

⚠ WARNING**LEAKAGE CURRENT HAZARD**

Leakage currents exceed 3.5 mA. Failure to ground the frequency converter properly can result in death or serious injury.

- Ensure the correct grounding of the equipment by a certified electrical installer.

⚠ WARNING**EQUIPMENT HAZARD**

Contact with rotating shafts and electrical equipment can result in death or serious injury.

- Ensure that only trained and qualified personnel perform installation, start-up, and maintenance.
- Ensure that electrical work conforms to national and local electrical codes.
- Follow the procedures in this guide.

⚠ CAUTION**INTERNAL FAILURE HAZARD**

An internal failure in the frequency converter can result in serious injury when the frequency converter is not properly closed.

- Ensure that all safety covers are in place and securely fastened before applying power.

3 Mechanical Installation

3.1 Unpacking

3.1.1 Items Supplied

Items supplied may vary according to product configuration.

- Make sure that the items supplied and the information on the nameplate correspond to the order confirmation.
- Check the packaging and the frequency converter visually for damage caused by inappropriate handling during shipment. File any claim for damage with the carrier. Retain damaged parts for clarification.



1	Product logo
2	Product name
3	Ordering number
4	Type code
5	Power rating
6	Input voltage, frequency, and current (at low/high voltages)
7	Output voltage, frequency, and current (at low/high voltages)
8	IP rating
9	Country of origin
10	Serial number
11	EAC logo
12	CE mark
13	TÜV logo
14	Disposal
15	Barcode
16	Reference to enclosure type
17	UL logo
18	UL reference
19	Warning specifications
20	RCM logo

Illustration 3.1 Product Nameplate (Example)

NOTICE

Do not remove the nameplate from the frequency converter (loss of warranty).

3.1.2 Storage

Ensure that requirements for storage are fulfilled. Refer to chapter 9.4 Ambient Conditions for further details.

3.2 Installation Environment

NOTICE

In environments with airborne liquids, particles, or corrosive gases, ensure that the IP/Type rating of the equipment matches the installation environment. Failure to meet requirements for ambient conditions can reduce lifetime of the frequency converter. Ensure that requirements for air humidity, temperature, and altitude are met.

Vibration and shock

The frequency converter complies with requirements for units mounted on the walls and floors of production premises, and in panels bolted to walls or floors.

For detailed ambient conditions specifications, refer to *chapter 9.4 Ambient Conditions*.

3.3 Mounting

NOTICE

Improper mounting can result in overheating and reduced performance.

Cooling

- Ensure 100 mm (3.9 in) of top and bottom clearance for air cooling.

Lifting

- To determine a safe lifting method, check the weight of the unit, see *chapter 9.9 Enclosure Sizes, Power Ratings, and Dimensions*.
- Ensure that the lifting device is suitable for the task.
- If necessary, plan for a hoist, crane, or forklift with the appropriate rating to move the unit.
- For lifting, use hoist rings on the unit, when provided.

Mounting

To adapt the mounting holes of VLT® Midi Drive FC 280, contact the local Danfoss supplier to order a separate backplate.

To mount the frequency converter:

1. Ensure that the mounting location is strong enough to support the unit weight. The frequency converter allows side-by-side installation.
2. Place the unit as close to the motor as possible. Keep the motor cables as short as possible.
3. Mount the unit vertically to a solid flat surface or to the optional backplate to provide cooling airflow.
4. When provided, use the slotted mounting holes on the unit for wall mounting.

NOTICE

For dimensions of mounting holes, see *chapter 9.9 Enclosure Sizes, Power Ratings, and Dimensions*.

3.3.1 Side-by-side Installation

Side-by-side installation

All VLT® Midi Drive FC 280 units can be installed side by side in vertical or horizontal position. The units do not require extra ventilation on the side.

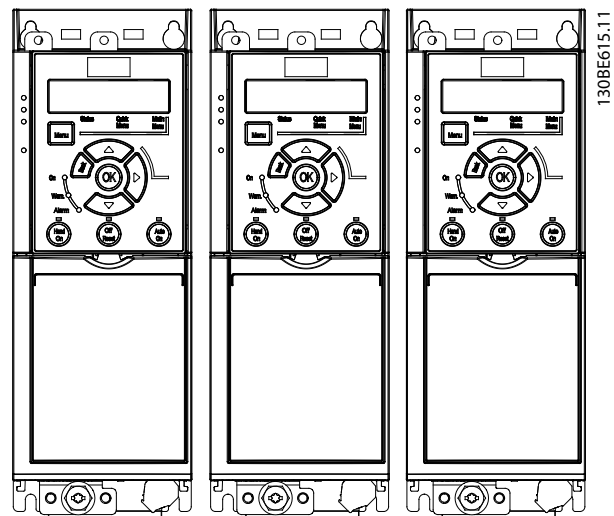

Illustration 3.2 Side-by-side Installation

NOTICE

RISK OF OVERHEATING

If IP21 conversion kit is used, mounting the units side by side could lead to overheating and damage to the unit.

- Avoid mounting the units side by side if IP21 conversion kit is used.

3.3.2 Bus Decoupling Kit

The bus decoupling kit ensures mechanical fixation and electrical shielding of cables for the following control cassette variants:

- Control cassette with PROFIBUS.
- Control cassette with PROFINET.
- Control cassette with CANopen.
- Control cassette with Ethernet.

Each bus decoupling kit contains 1 horizontal decoupling plate and 1 vertical decoupling plate. Mounting the vertical decoupling plate is optional. The vertical decoupling plate provides better mechanical support for PROFINET and Ethernet connectors and cables.

3.3.3 Mounting

To mount the bus decoupling kit:

1. Place the horizontal decoupling plate on the control cassette mounted on the frequency converter and fasten the plate using 2 screws as shown in *Illustration 3.3*. Tightening torque is 0.7–1.0 Nm (6.2–8.9 in-lb).
2. Optional: Mount the vertical decoupling plate as follows:
 - 2a Remove the 2 mechanical springs and 2 metal clamps from the horizontal plate.
 - 2b Mount the mechanical springs and metal clamps on the vertical plate.
 - 2c Fasten the plate with 2 screws as shown in *Illustration 3.4*. Tightening torque is 0.7–1.0 Nm (6.2–8.9 in-lb).

NOTICE

If the IP21 top cover is used, do not mount the vertical decoupling plate, because its height affects the proper installation of the IP21 top cover.

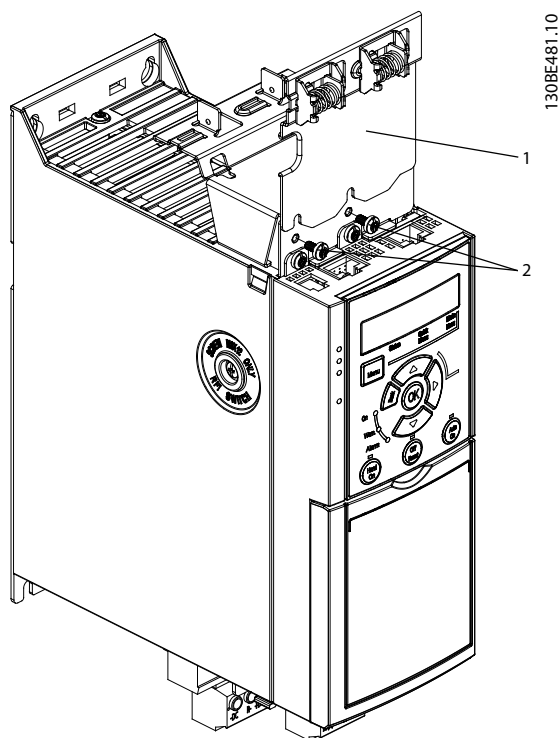

130BE481.10

3

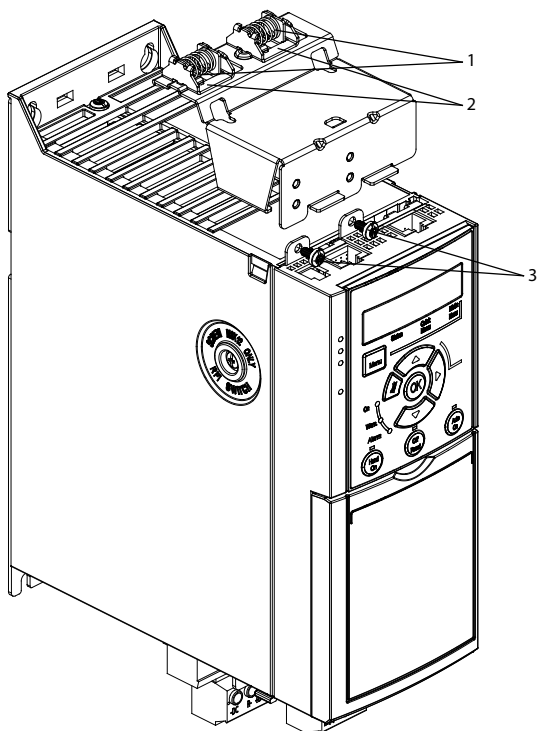

130BE480.10

1	Vertical decoupling plate
2	Screws

Illustration 3.4 Fasten the Vertical Decoupling Plate with Screws

Both *Illustration 3.3* and *Illustration 3.4* show PROFINET sockets. The actual sockets are based on the type of the control cassette mounted on the frequency converter.

3. Push the PROFIBUS/PROFINET/CANopen/Ethernet cable connectors into the sockets in the control cassette.
4.
 - 4a Place the PROFIBUS/CANopen cables between the spring-loaded metal clamps to establish mechanical fixation and electrical contact between the shielded sections of the cables and the clamps.
 - 4b Place the PROFINET/Ethernet cables between the spring-loaded metal clamps to establish mechanical fixation between the cables and the clamps.

1	Mechanical springs
2	Metal clamps
3	Screws

Illustration 3.3 Fasten the Horizontal Decoupling Plate with Screws

4 Electrical Installation

4.1 Safety Instructions

See *chapter 2 Safety* for general safety instructions.

⚠ WARNING

INDUCED VOLTAGE

Induced voltage from output motor cables of different frequency converters that run together can charge equipment capacitors even with the equipment turned off and locked out. Failure to run output motor cables separately or use shielded cables could result in death or serious injury.

- Run output motor cables separately.
- Use shielded cables.
- Lock out all the frequency converters simultaneously.

⚠ WARNING

SHOCK HAZARD

The frequency converter can cause a DC current in the PE conductor and hence result in death or serious injury.

- When a residual current-operated protective device (RCD) is used for protection against electrical shock, only an RCD of Type B is allowed on the supply side.

Failure to follow the recommendation means that the RCD cannot provide the intended protection.

Overcurrent protection

- Extra protective equipment such as short-circuit protection or motor thermal protection between frequency converter and motor is required for applications with multiple motors.
- Input fusing is required to provide protection against short circuit and overcurrent. If fuses are not factory-supplied, the installer must provide them. See maximum fuse ratings in *chapter 9.8 Fuses and Circuit Breakers*.

Wire type and ratings

- All wiring must comply with local and national regulations regarding cross-section and ambient temperature requirements.
- Power connection wire recommendation: Minimum 75 °C (167 °F) rated copper wire.

See *chapter 9.5 Cable Specifications* for recommended wire sizes and types.

4.2 EMC-compliant Installation

To obtain an EMC-compliant installation, follow the instructions provided in *chapter 4.3 Grounding*, *chapter 4.4 Wiring Schematic*, *chapter 4.6 Motor Connection*, and *chapter 4.8 Control Wiring*.

4.3 Grounding

⚠ WARNING

LEAKAGE CURRENT HAZARD

Leakage currents exceed 3.5 mA. Failure to ground the frequency converter properly could result in death or serious injury.

- Ensure the correct grounding of the equipment by a certified electrical installer.

For electrical safety

- Ground the frequency converter in accordance with applicable standards and directives.
- Use a dedicated ground wire for input power, motor power, and control wiring.
- Do not ground 1 frequency converter to another in a daisy-chain fashion (see *Illustration 4.1*).
- Keep the ground wire connections as short as possible.
- Follow motor manufacturer wiring requirements.
- Minimum cable cross-section: 10 mm² (7 AWG). Separately terminate 2 ground wires, both complying with the dimension requirements.

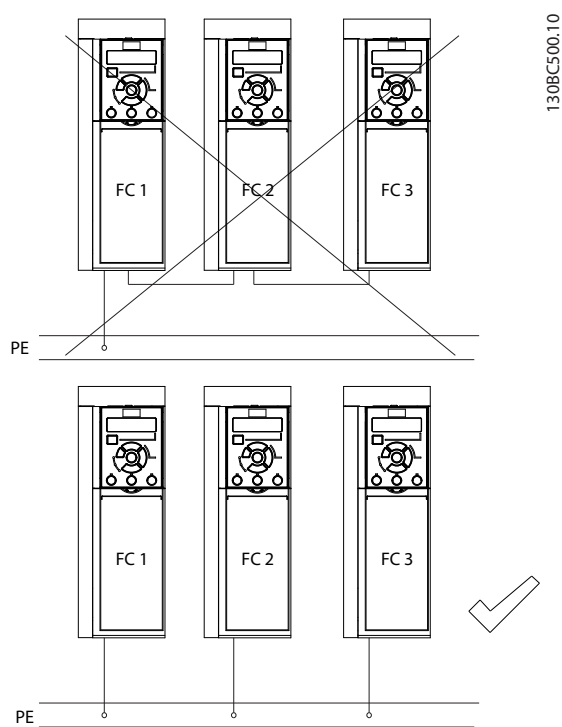

Illustration 4.1 Grounding Principle

For EMC-compliant installation

- Establish electrical contact between the cable shield and the frequency converter enclosure by using metal cable glands or by using the clamps provided on the equipment (see *chapter 4.6 Motor Connection*).
- Use high-strand wire to reduce burst transient.
- Do not use pigtails.

NOTICE

POTENTIAL EQUALIZATION

Risk of burst transient when the ground potential between the frequency converter and the control system is different. Install equalizing cables between the system components. Recommended cable cross-section: 16 mm² (6 AWG).

4.4 Wiring Schematic

This section describes how to wire the frequency converter.

4

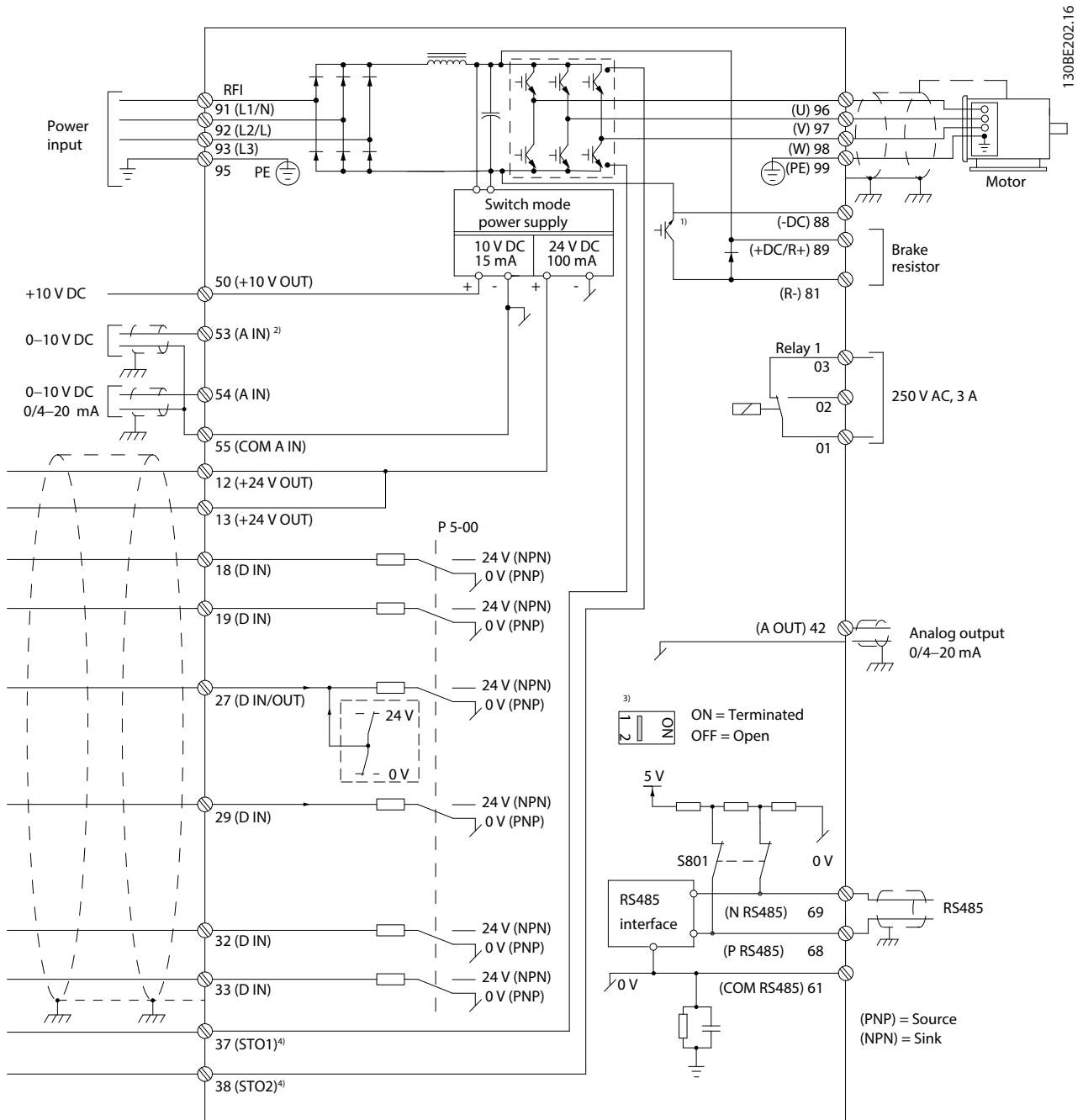

Illustration 4.2 Basic Wiring Schematic Drawing

A=Analog, D=Digital

1) Built-in brake chopper is only available on 3-phase units.

2) Terminal 53 can also be used as digital input.

3) Switch S801 (bus terminal) can be used to enable termination on the RS485 port (terminals 68 and 69).

4) Refer to chapter 6 Safe Torque Off (STO) for the correct STO wiring.

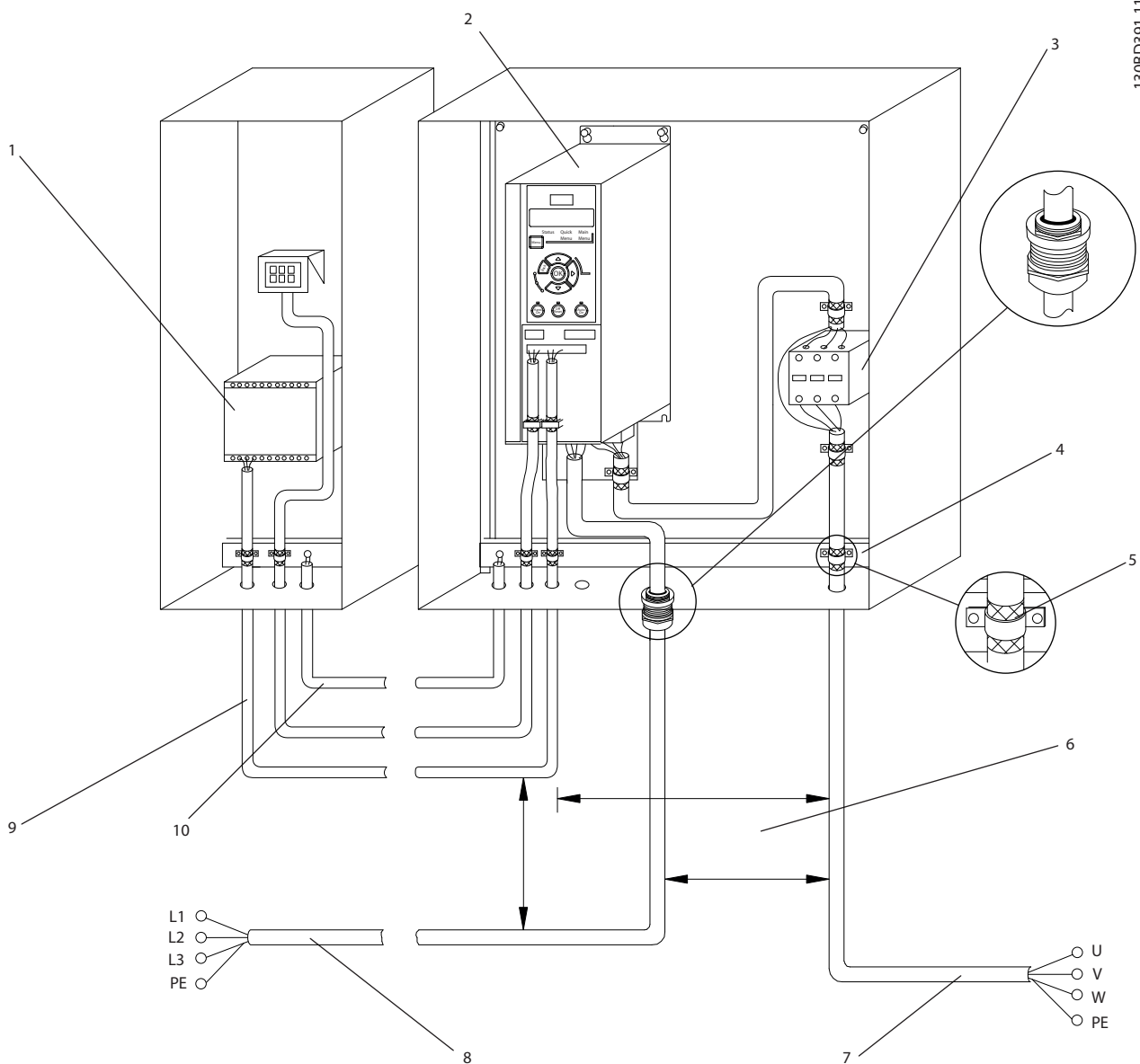

1	PLC	6	Minimum 200 mm (7.9 in) between control cables, motor, and mains
2	Frequency converter	7	Motor, 3-phase and PE
3	Output contactor (not recommended)	8	Mains, single-phase, 3-phase, and reinforced PE
4	Grounding rail (PE)	9	Control wiring
5	Cable shielding (stripped)	10	Equalizing minimum 16 mm ² (6 AWG)

Illustration 4.3 Typical Electrical Connection

4.5 Access

- Remove the cover plate with a screwdriver. See *Illustration 4.4*.

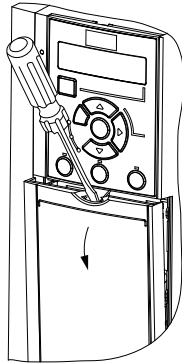

130B5341.1

Illustration 4.4 Control Wiring Access

4.6 Motor Connection

⚠ WARNING

INDUCED VOLTAGE

Induced voltage from output motor cables that run together can charge equipment capacitors, even when the equipment is turned off and locked out. Failure to run output motor cables separately or use shielded cables could result in death or serious injury.

- Run output motor cables separately.
- Use shielded cables.
- Comply with local and national electrical codes for cable sizes. For maximum cable sizes, see *chapter 9.1 Electrical Data*.
- Follow motor manufacturer wiring requirements.
- Motor wiring knockouts or access panels are provided at the base of IP21 (NEMA1/12) units.
- Do not wire a starting or pole-changing device (for example, Dahlander motor or slip ring induction motor) between the frequency converter and the motor.

Procedure

- Strip a section of the outer cable insulation.
- Position the stripped cable under the cable clamp to establish mechanical fixation and electrical contact between the cable shield and ground.
- Connect the ground cable to the nearest grounding terminal in accordance with the grounding instructions provided in *chapter 4.3 Grounding*. See *Illustration 4.5*.
- Connect the 3-phase motor wiring to terminals 96 (U), 97 (V), and 98 (W), as shown in *Illustration 4.5*.

- Tighten the terminals in accordance with the information provided in *chapter 9.7 Connection Tightening Torques*.

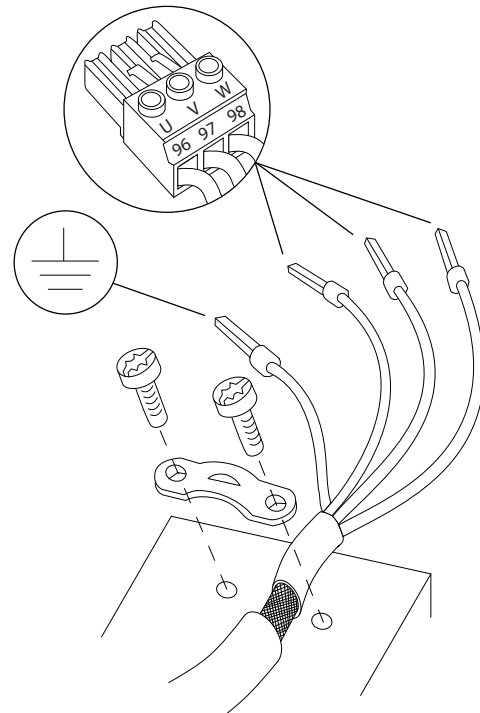

130B531.10

Illustration 4.5 Motor Connection

The mains, motor, and grounding connection for single-phase and 3-phase frequency converters are shown in *Illustration 4.6* and *Illustration 4.7*, respectively. Actual configurations vary with unit types and optional equipment.

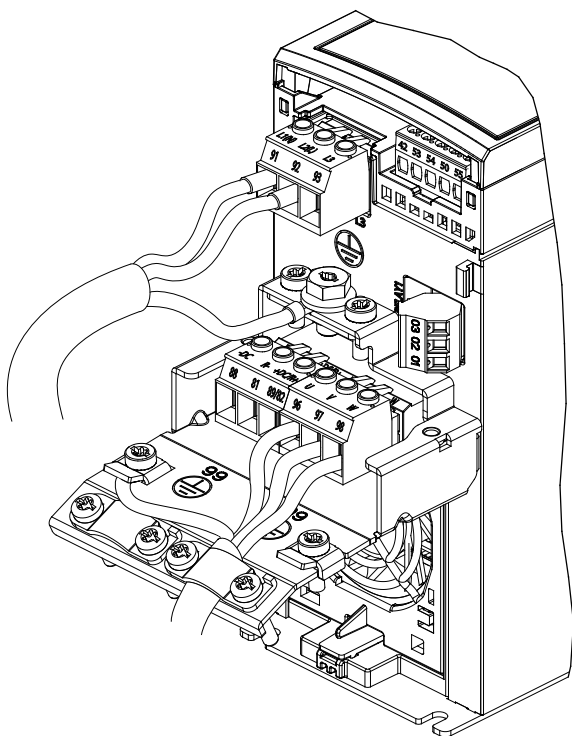

130BE232.11

Illustration 4.6 Mains, Motor, and Grounding Connection for Single-phase Units

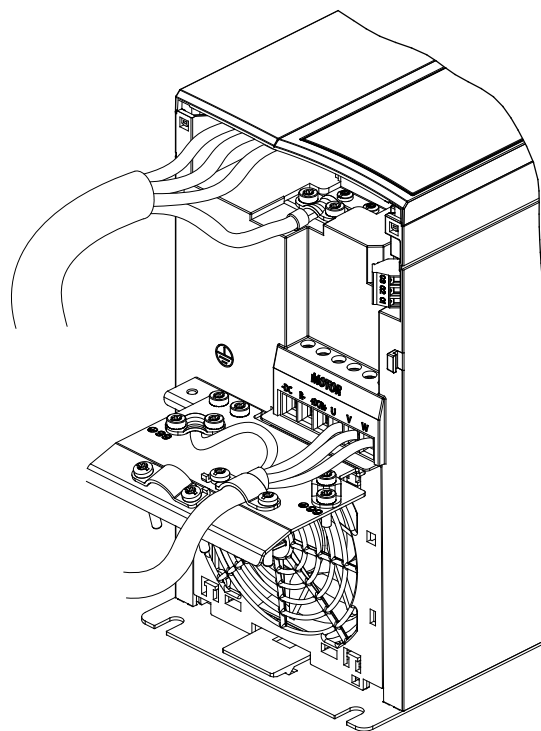

130BE804.10

Illustration 4.8 Mains, Motor, and Grounding Connection for 3-phase Units (K4, K5)

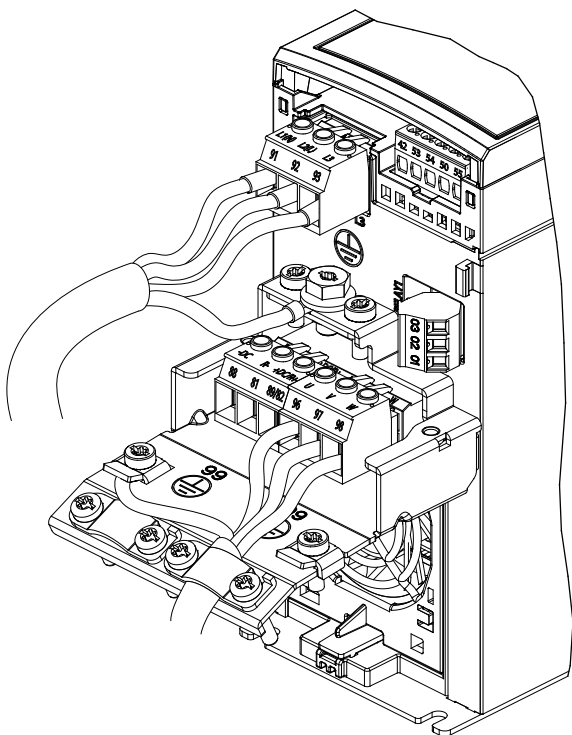

130BE231.11

Illustration 4.7 Mains, Motor, and Grounding Connection for 3-phase Units

4.7 AC Mains Connection

- Size the wiring based on the input current of the frequency converter. For maximum wire sizes, see *chapter 9.1 Electrical Data*.
- Comply with local and national electrical codes for cable sizes.

Procedure

1. Connect the AC input power cables to terminals N and L for single-phase units (see *Illustration 4.6*), or to terminals L1, L2, and L3 for 3-phase units (see *Illustration 4.7*).
2. Depending on the configuration of the equipment, connect the input power to the mains input terminals or the input disconnect.
3. Ground the cable in accordance with the grounding instructions in *chapter 4.3 Grounding*.
4. When supplied from an isolated mains source (IT mains or floating delta) or TT/TN-S mains with a grounded leg (grounded delta), ensure that the RFI filter screw is removed. Removing the RFI screw prevents damage to the DC link and reduces ground capacity currents in accordance with IEC 61800-3.

4.8 Control Wiring

4.8.1 Control Terminal Types

Illustration 4.9 shows the removable frequency converter connectors. Terminal functions and default settings are summarized in Table 4.1 and Table 4.2.

4

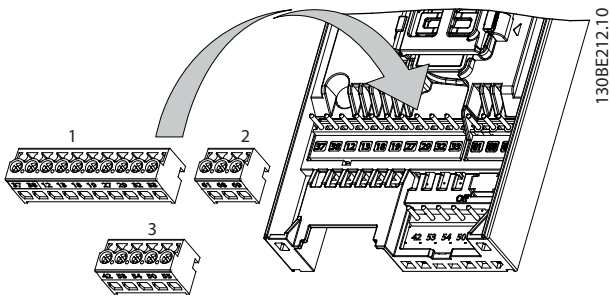

Illustration 4.9 Control Terminal Locations

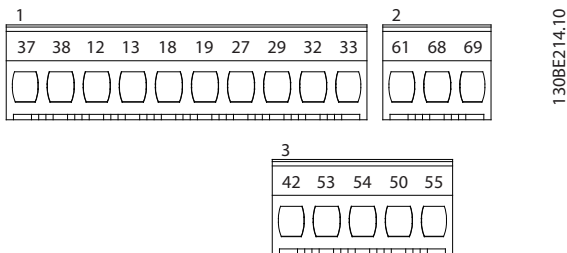

Illustration 4.10 Terminal Numbers

See chapter 9.6 Control Input/Output and Control Data for terminal ratings details.

Terminal	Parameter	Default setting	Description
Digital I/O, pulse I/O, encoder			
12, 13	–	+24 V DC	24 V DC supply voltage. Maximum output current is 100 mA for all 24 V loads.
18	Parameter 5-10 Terminal 18 Digital Input	[8] Start	Digital inputs.
19	Parameter 5-11 Terminal 19 Digital Input	[10] Reversing	

Terminal	Parameter	Default setting	Description
27	Parameter 5-01 Terminal 27 Mode Parameter 5-12 Terminal 27 Digital Input Parameter 5-30 Terminal 27 Digital Output	DI [2] Coast inverse DO [0] No operation	Selectable for either digital input, digital output, or pulse output. The default setting is digital input.
29	Parameter 5-13 Terminal 29 Digital Input	[14] Jog	Digital input.
32	Parameter 5-14 Terminal 32 Digital Input	[0] No operation	Digital input, 24 V encoder. Terminal 33 can be used for pulse input.
33	Parameter 5-15 Terminal 33 Digital Input	[0] No operation	
37, 38	–	STO	Functional safety inputs.
Analog inputs/outputs			
42	Parameter 6-91 Terminal 42 Analog Output	[0] No operation	Programmable analog output. The analog signal is 0–20 mA or 4–20 mA at a maximum of 500 Ω. Can also be configured as digital outputs.
50	–	+10 V DC	10 V DC analog supply voltage. 15 mA maximum commonly used for potentiometer or thermistor.
53	Parameter group 6-1* Analog input 53	–	Analog input. Only voltage mode is supported. It can also be used as digital input.
54	Parameter group 6-2* Analog input 54	–	Analog input. Selectable between voltage or current mode.
55	–	–	Common for digital and analog inputs.

Table 4.1 Terminal Descriptions - Digital Inputs/Outputs, Analog Inputs/Outputs

Terminal	Parameter	Default setting	Description
Serial communication			
61	-	-	Integrated RC filter for cable shield. ONLY for connecting the shield when experiencing EMC problems.
68 (+)	Parameter group 8-3* FC port settings	-	RS485 interface. A control card switch is provided for termination resistance.
69 (-)	Parameter group 8-3* FC port settings	-	
Relays			
01, 02, 03	Parameter 5-40 Function Relay	[1] Control Ready	Form C relay output. These relays are in various locations depending on the frequency converter configuration and size. Usable for AC or DC voltage and resistive or inductive loads.

Table 4.2 Terminal Descriptions - Serial Communication

4.8.2 Wiring to Control Terminals

Control terminal connectors can be unplugged from the frequency converter for ease of installation, as shown in *Illustration 4.9*.

For details about STO wiring, refer to *chapter 6 Safe Torque Off (STO)*.

NOTICE

Keep control cables as short as possible and separate them from high-power cables to minimize interference.

1. Loosen the screws for the terminals.
2. Insert sleeved control cables into the slots.
3. Fasten the screws for the terminals.
4. Ensure that the contact is firmly established and not loose. Loose control wiring can be the source of equipment faults or less than optimal operation.

See *chapter 9.5 Cable Specifications* for control terminal cable sizes and *chapter 7 Application Examples* for typical control cable connections.

4.8.3 Enabling Motor Operation (Terminal 27)

A jumper wire is required between terminal 12 (or 13) and terminal 27 for the frequency converter to operate when using factory default programming values.

- Digital input terminal 27 is designed to receive 24 V DC external interlock command.
- When no interlock device is used, wire a jumper between control terminal 12 (recommended) or 13 to terminal 27. The jumper provides an internal 24 V signal on terminal 27.
- Only for GLCP: When the status line at the bottom of the LCP reads *AUTO REMOTE COAST*, it indicates that the unit is ready to operate but is missing an input signal on terminal 27.

NOTICE

UNABLE TO START

The frequency converter cannot operate without a signal on terminal 27, unless terminal 27 is reprogrammed.

4.8.4 Mechanical Brake Control

In hoisting/lowering applications, it is necessary to control an electro-mechanical brake.

- Control the brake using any relay output or digital output (terminal 27).
- Keep the output closed (voltage-free) as long as the frequency converter is unable to keep the motor at standstill, for example due to the load being too heavy.
- Select [32] *Mechanical brake control* in parameter group 5-4* *Relays* for applications with an electro-mechanical brake.
- The brake is released when the motor current exceeds the preset value in parameter 2-20 *Release Brake Current*.
- The brake is engaged when the output frequency is less than the frequency set in parameter 2-22 *Activate Brake Speed [Hz]*, and only if the frequency converter carries out a stop command.

If the frequency converter is in alarm mode or in an overvoltage situation, the mechanical brake immediately closes.

The frequency converter is not a safety device. It is the responsibility of the system designer to integrate safety devices according to relevant national crane/lift regulations.

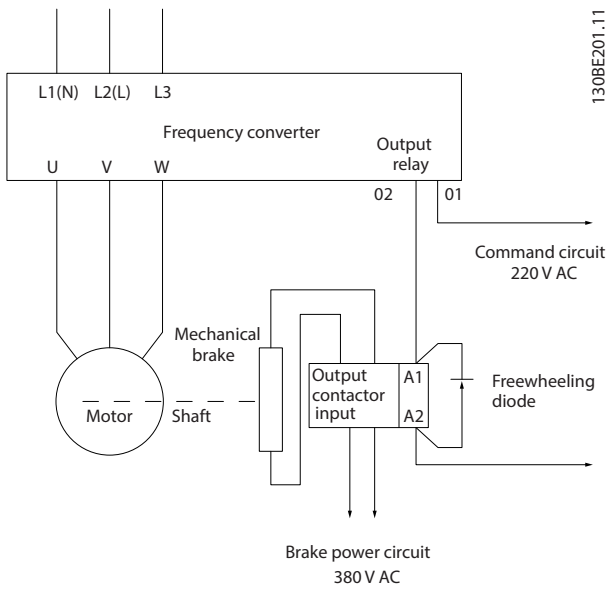

Illustration 4.11 Connecting the Mechanical Brake to the Frequency Converter

4.8.5 USB Data Communication

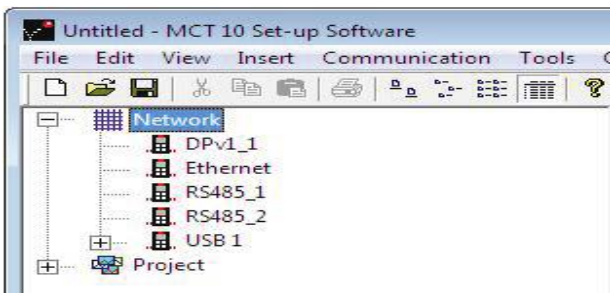

Illustration 4.12 Network Bus List

When the USB cable is disconnected, the frequency converter connected via the USB port is removed from the *Network* bus list.

NOTICE

A USB bus has no address-setting capacity and no bus name to configure. If connecting more than 1 frequency converter through USB, the bus name is auto-incremented in the MCT 10 Set-up Software Network bus list.

Connecting more than 1 frequency converter through a USB cable often causes computers installed with Windows XP to throw an exception and crash. Therefore it is advised only to connect 1 frequency converter via USB to the PC.

4.8.6 RS485 Serial Communication

Connect RS485 serial communication wiring to terminals (+)68 and (-)69.

- Shielded serial communication cable is recommended.
- See *chapter 4.3 Grounding* for proper grounding.

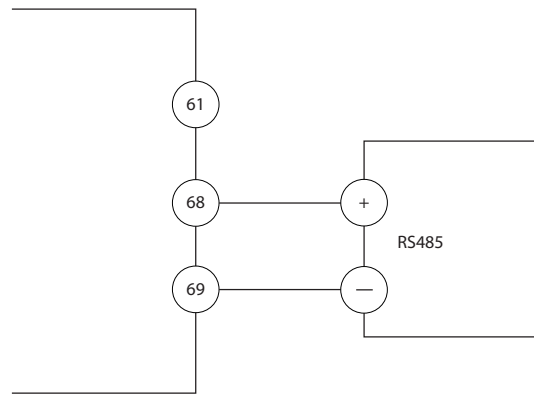

Illustration 4.13 Serial Communication Wiring Diagram

For basic serial communication set-up, select the following:

1. Protocol type in *parameter 8-30 Protocol*.
2. Frequency converter address in *parameter 8-31 Address*.
3. Baud rate in *parameter 8-32 Baud Rate*.

Two communication protocols are internal to the frequency converter. Follow motor manufacturer wiring requirements.

- Danfoss FC
- Modbus RTU

Functions can be programmed remotely using the protocol software and RS485 connection, or in *parameter group 8-3** Communications and Options*.

Selecting a specific communication protocol changes various default parameter settings to match the speci-

cations of the protocol and makes extra protocol-specific parameters available.

4.9 Installation Checklist

Before completing installation of the unit, inspect the entire installation as detailed in *Table 4.3*. Check and mark the items when completed.

Inspect for	Description	<input checked="" type="checkbox"/>
Auxiliary equipment	<ul style="list-style-type: none"> Look for auxiliary equipment, switches, disconnects, or input fuses/circuit breakers, which may reside on the input power side of the frequency converter or output side to the motor. Ensure that they are ready for full-speed operation. Check the function and installation of any sensors used for feedback to the frequency converter. Remove any power factor correction capacitors on the motor(s). Adjust any power factor correction capacitors on the mains side and ensure that they are dampened. 	
Cable routing	<ul style="list-style-type: none"> Ensure that the motor wiring and control wiring are separated, shielded, or in 3 separate metallic conduits for high frequency interference isolation. 	
Control wiring	<ul style="list-style-type: none"> Check for broken or damaged wires and loose connections. Check that the control wiring is isolated from power and motor wiring for noise immunity. Check the voltage source of the signals, if necessary. <p>The use of shielded cable or twisted pair is recommended. Ensure that the shield is terminated correctly.</p>	
Cooling clearance	<ul style="list-style-type: none"> Ensure that the top and bottom clearance is adequate to ensure proper airflow for cooling, see <i>chapter 3.3 Mounting</i>. 	
Ambient conditions	<ul style="list-style-type: none"> Check that requirements for ambient conditions are met. 	
Fusing and circuit breakers	<ul style="list-style-type: none"> Check for proper fusing or circuit breakers. Check that all fuses are inserted firmly and are in operational condition and that all circuit breakers are in the open position. 	
Grounding	<ul style="list-style-type: none"> Check for sufficient ground connections and ensure that they are tight and free of oxidation. Do not ground to conduit, or mount the back panel to a metal surface. 	
Input and output power wiring	<ul style="list-style-type: none"> Check for loose connections. Check that the motor and mains cables are in separate conduit or separated shielded cables. 	
Panel interior	<ul style="list-style-type: none"> Inspect that the unit interior is free of dirt, metal chips, moisture, and corrosion. Check that the unit is mounted on an unpainted, metal surface. 	
Switches	<ul style="list-style-type: none"> Ensure that all switch and disconnect settings are in the proper positions. 	
Vibration	<ul style="list-style-type: none"> Check that the unit is mounted solidly, or that shock mounts are used, as necessary. Check for an unusual amount of vibration. 	

Table 4.3 Installation Check List

CAUTION

POTENTIAL HAZARD IN THE EVENT OF INTERNAL FAILURE

Risk of personal injury if the frequency converter is not properly closed.

- Before applying power, ensure that all safety covers are in place and securely fastened.

5 Commissioning

5.1 Safety Instructions

See *chapter 2 Safety* for general safety instructions.

⚠ WARNING

HIGH VOLTAGE

Frequency converters contain high voltage when connected to AC mains input power. Failure to perform installation, start-up, and maintenance by qualified personnel could result in death or serious injury.

- Installation, start-up, and maintenance must be performed by qualified personnel only.

Before applying power:

1. Close the cover properly.
2. Check that all cable glands are firmly tightened.
3. Ensure that input power to the unit is off and locked out. Do not rely on the frequency converter disconnect switches for input power isolation.
4. Verify that there is no voltage on input terminals L1 (91), L2 (92), and L3 (93), phase-to-phase, and phase-to-ground.
5. Verify that there is no voltage on output terminals 96 (U), 97 (V), and 98 (W), phase-to-phase, and phase-to-ground.
6. Confirm continuity of the motor by measuring Ω values on U–V (96–97), V–W (97–98), and W–U (98–96).
7. Check for proper grounding of the frequency converter and the motor.
8. Inspect the frequency converter for loose connections on the terminals.
9. Confirm that the supply voltage matches the voltage of the frequency converter and the motor.

5.2 Applying Power

Apply power to the frequency converter using the following steps:

1. Confirm that the input voltage is balanced within 3%. If not, correct the input voltage imbalance before proceeding. Repeat this procedure after the voltage correction.
2. Ensure that any optional equipment wiring matches the installation application.

3. Ensure that all operator devices are in the OFF position. Panel doors must be closed and covers securely fastened.
4. Apply power to the unit. Do not start the frequency converter now. For units with a disconnect switch, turn it to the ON position to apply power to the frequency converter.

5.3 Local Control Panel Operation

The frequency converter supports numerical local control panel (NLCP), graphic local control panel (GLCP), and blind cover. This section describes the operations with NLCP and GLCP.

NOTICE

The frequency converter can also be programmed from the MCT 10 Set-up Software on PC via RS485 communication port or USB port. This software can be ordered using code number 130B1000 or downloaded from the Danfoss website: www.danfoss.com/BusinessAreas/Drives-Solutions/softwaredownload.

5.3.1 Numeric Local Control Panel (LCP)

The numerical local control panel (NLCP) is divided into 4 functional sections.

- A. Numeric display.
- B. Menu key.
- C. Navigation keys and indicator lights (LEDs).
- D. Operation keys and indicator lights (LEDs).

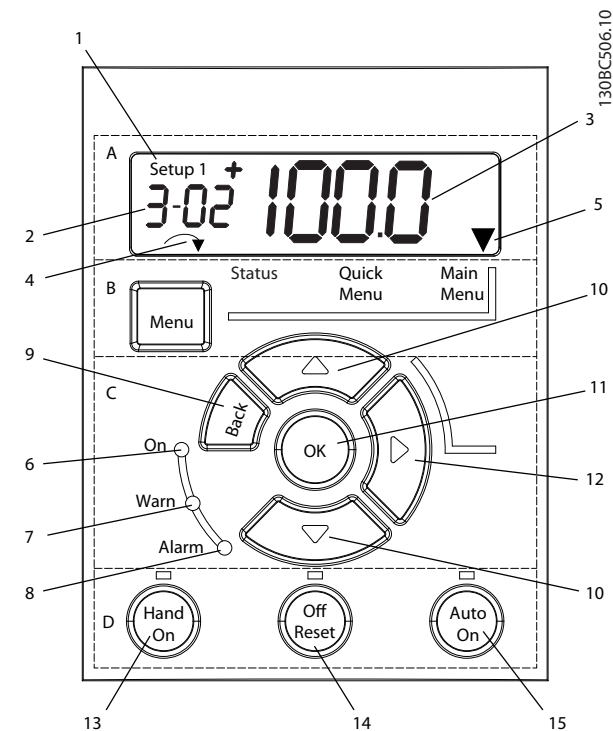

Illustration 5.1 View of the NLCP

A. Numeric display

The LCD display is backlit with 1 numeric line. All data is shown in the NLCP.

1	The set-up number shows the active set-up and the edit set-up. If the same set-up acts as both active and edit set-up, only that set-up number is shown (factory setting). When active and edit set-up differ, both numbers are shown in the display (for example set-up 12). The number flashing indicates the edit set-up.
2	Parameter number.
3	Parameter value.
4	Motor direction is shown at the bottom left of the display. A small arrow indicates the direction.
5	The triangle indicates whether the LCP is in Status, Quick Menu, or Main Menu.

Table 5.1 Legend to Illustration 5.1, Section A



Illustration 5.2 Display Information

B. Menu key

To select between Status, Quick Menu, or Main Menu, press [Menu].

C. Indicator lights (LEDs) and navigation keys

	Indicator	Light	Function
6	On	Green	ON turns on when the frequency converter receives power from the mains voltage, a DC bus terminal, or a 24 V external supply.
7	Warn	Yellow	When warning conditions are met, the yellow WARN light turns on, and text appears in the display area identifying the problem.
8	Alarm	Red	A fault condition causes the red alarm light to flash and an alarm text is shown.

Table 5.2 Legend to Illustration 5.1, Indicator Lights (LEDs)

	Key	Function
9	[Back]	For moving to the previous step or layer in the navigation structure.
10	Arrows [▲] [▼]	For switching between parameter groups, parameters, and within parameters, or increasing/decreasing parameter values. Arrows can also be used for setting local reference.
11	[OK]	Press to access parameter groups or to enable a selection.
12	[▶]	Press to move from left to right within the parameter value to change each digit individually.

Table 5.3 Legend to Illustration 5.1, Navigation Keys

D. Operation keys and indicator lights (LEDs)

	Key	Function
13	Hand On	Starts the frequency converter in local control. <ul style="list-style-type: none"> An external stop signal by control input or serial communication overrides the local hand on.
14	Off/Reset	Stops the motor but does not remove power to the frequency converter or resets the frequency converter manually after a fault has been cleared.
15	Auto On	Puts the system in remote operational mode. <ul style="list-style-type: none"> Responds to an external start command by control terminals or serial communication.

Table 5.4 Legend to Illustration 5.1, Section D

⚠ WARNING**ELECTRICAL HAZARD**

Even after pressing the [Off/Reset] key, voltage is present at the terminals of the frequency converter. Pressing the [Off/Reset] key does not disconnect the frequency converter from mains. Touching live parts can result in death or serious injury.

- Do not touch any live parts.

5.3.2 The Right-key Function on NLCP

Press [▶] to edit any of the 4 digits on the display individually. When pressing [▶] once, the cursor moves to the first digit, and the digit starts flashing as shown in *Illustration 5.3*. Press the [▲] [▼] to change the value. Pressing [▶] does not change the value of the digits, or move the decimal point.

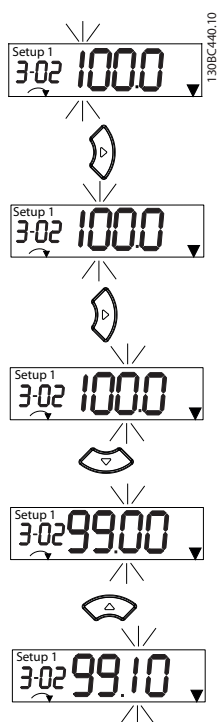

Illustration 5.3 Right-key Function

[▶] can also be used for moving between parameter groups. When in Main Menu, press [▶] to move to the first parameter in the next parameter group (for example, move from *parameter 0-03 Regional Settings [0] International* to *parameter 1-00 Configuration Mode [0] Open loop*).

NOTICE

During start-up, the LCP shows the message *INITIALISING*. When this message is no longer shown, the frequency converter is ready for operation. Adding or removing options can extend the duration of start-up.

5.3.3 Quick Menu on NLCP

The *Quick Menu* gives easy access to the most frequently used parameters.

1. To enter *Quick Menu*, press [Menu] until the indicator in the display is placed above *Quick Menu*.
2. Press [▲] [▼] to select either QM1 or QM2, then press [OK].
3. Press [▲] [▼] to browse through the parameters in *Quick Menu*.
4. Press [OK] to select a parameter.
5. Press [▲] [▼] to change the value of a parameter setting.
6. Press [OK] to accept the change.
7. To exit, press either [Back] twice (or 3 times if in QM2 and QM3) to enter *Status*, or press [Menu] once to enter *Main Menu*.

130BC445.12

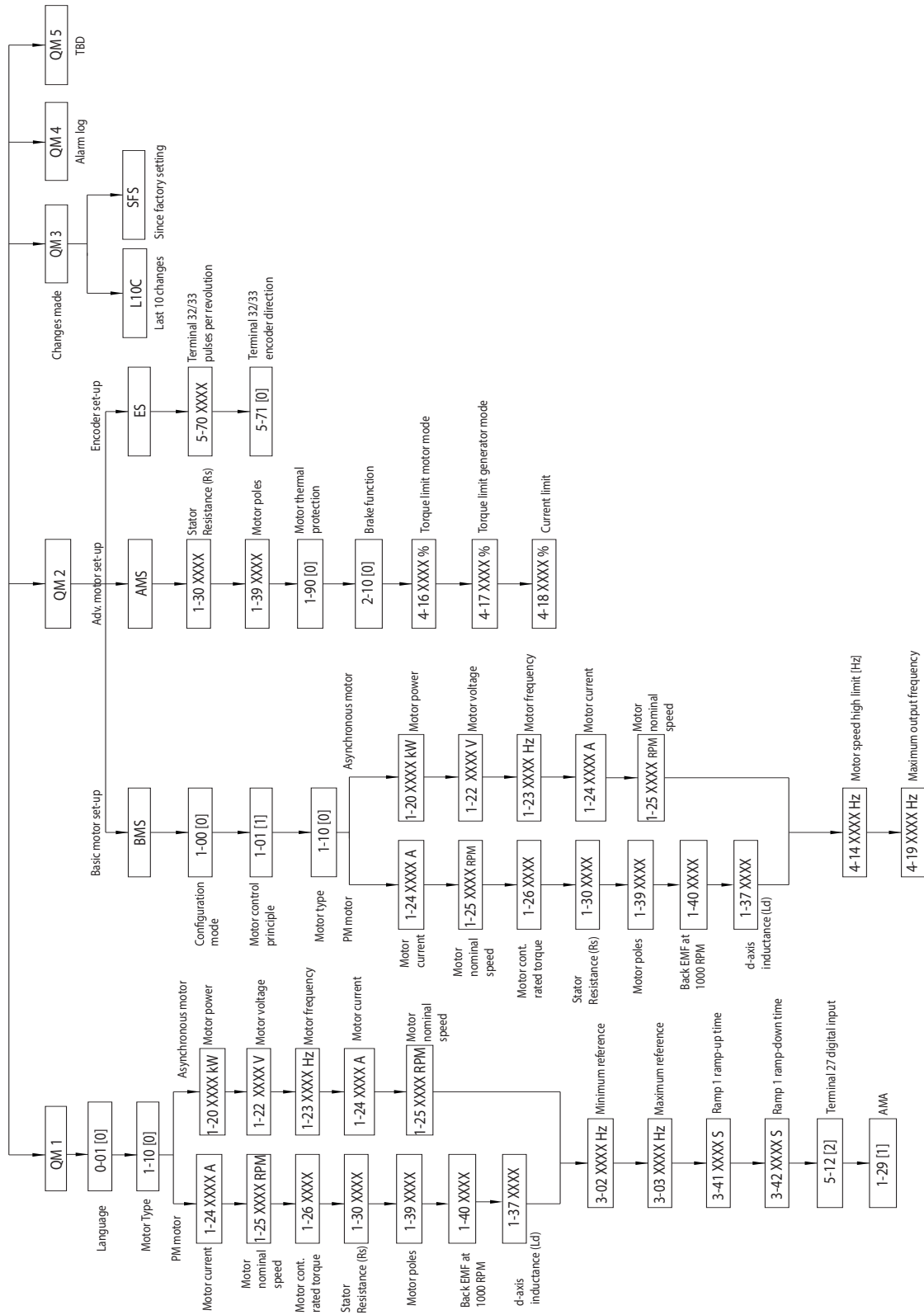

Illustration 5.4 Quick Menu Structure

5.3.4 Main Menu on NLCP

The *Main Menu* gives access to all parameters.

1. To enter *Main Menu*, press [Menu] until the indicator in the display is placed above *Main Menu*.
2. [▲] [▼]: Browse through the parameter groups.
3. Press [OK] to select a parameter group.
4. [▲] [▼]: Browse through the parameters in the specific group.
5. Press [OK] to select the parameter.
6. [▶] and [▲] [▼]: Set/change the parameter value.
7. Press [OK] to accept the value.
8. To exit, press either [Back] twice (or 3 times for array parameters) to enter *Main Menu*, or press [Menu] once to enter *Status*.

See *Illustration 5.5*, *Illustration 5.6*, and *Illustration 5.7* for the principles of changing the value of continuous, enumerated, and array parameters, respectively. The actions in the illustrations are described in *Table 5.5*, *Table 5.6*, and *Table 5.7*.

5

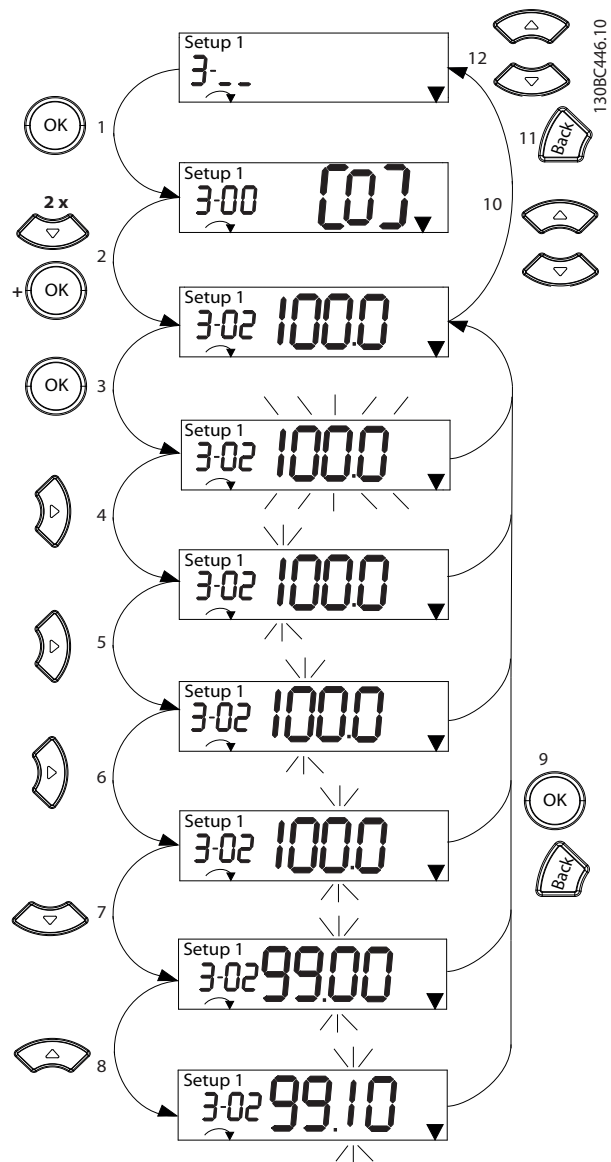

Illustration 5.5 Main Menu Interactions - Continuous Parameters

1	[OK]: The first parameter in the group is shown.
2	Press [▼] repeatedly to move down to the parameter.
3	Press [OK] to start editing.
4	[▶]: First digit flashing (can be edited).
5	[▶]: Second digit flashing (can be edited).
6	[▶]: Third digit flashing (can be edited).
7	[▼]: Decrease the parameter value, the decimal point changes automatically.
8	[▲]: Increase the parameter value.
9	[Back]: Cancel changes, return to 2. [OK]: Accept changes, return to 2.
10	[▲][▼]: Select parameter within the group.
11	[Back]: Remove the value and show the parameter group.
12	[▲][▼]: Select group.

Table 5.5 Changing Values in Continuous Parameters

For enumerated parameters, the interaction is similar, but the parameter value is shown in brackets because of the digits limitation (4 large digits) on the NLCP, and the enum can be greater than 99. When the enum value is greater than 99, the LCP can only show the first part of the bracket.

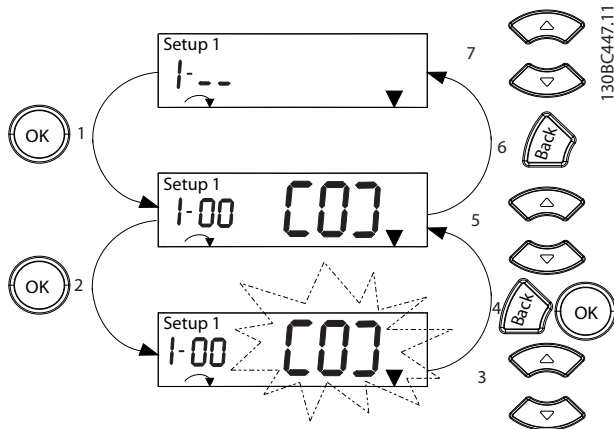

Illustration 5.6 Main Menu Interactions - Enumerated Parameters

1	[OK]: The first parameter in the group is shown.
2	Press [OK] to start editing.
3	[▲][▼]: Change parameter value (flashing).
4	Press [Back] to cancel changes or [OK] to accept changes (return to screen 2).
5	[▲][▼]: Select a parameter within the group.
6	[Back]: Remove the value and show the parameter group.
7	[▲][▼]: Select a group.

Table 5.6 Changing Values in Enumerated Parameters

Array parameters function as follows:

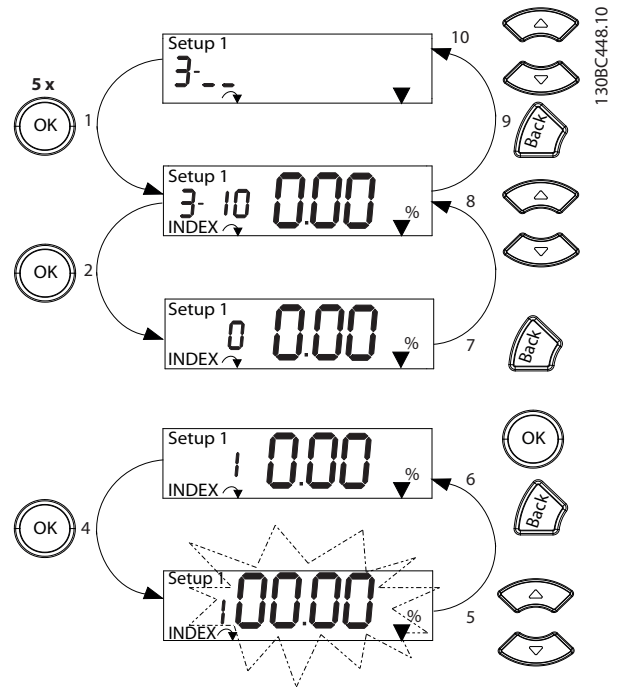

Illustration 5.7 Main Menu Interactions - Array Parameters

1	[OK]: Show parameter numbers and the value in the first index.
2	[OK]: Index can be selected.
3	[▲][▼]: Select index.
4	[OK]: Value can be edited.
5	[▲][▼]: Change parameter value (flashing).
6	[Back]: Cancel changes. [OK]: Accept changes.
7	[Back]: Cancel editing index, select a new parameter.
8	[▲][▼]: Select parameter within the group.
9	[Back]: Remove parameter index value and show the parameter group.
10	[▲][▼]: Select group.

Table 5.7 Changing Values in Array Parameters

5.3.5 GLCP Layout

The GLCP is divided into 4 functional groups (see *Illustration 5.8*).

- A. Display area
- B. Display menu keys
- C. Navigation keys and indicator lights (LEDs)
- D. Operation keys and reset

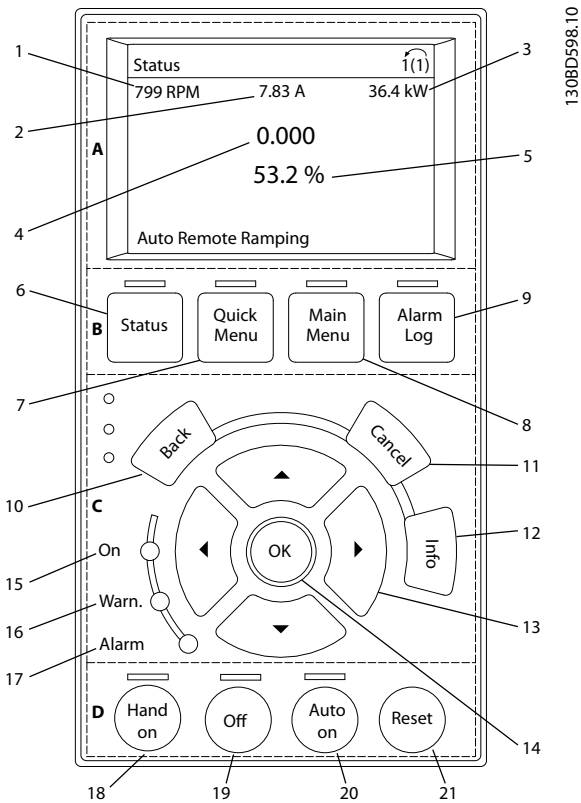

Illustration 5.8 Graphic Local Control Panel (GLCP)

A. Display area

The display area is activated when the frequency converter receives power from the mains voltage, a DC bus terminal, or a 24 V DC external supply.

The information shown on the LCP can be customized for user applications. Select options in the *Quick Menu Q3-13 Display Settings*.

Display	Parameter number	Default setting
1	0-20	[1602] Reference [%]
2	0-21	[1614] Motor Current
3	0-22	[1610] Power [kW]
4	0-23	[1613] Frequency
5	0-24	[1502] kWh Counter

Table 5.8 Legend to *Illustration 5.8*, Display Area

B. Display menu keys

Menu keys are used for menu access for parameter set-up, toggling through status display modes during normal operation, and viewing fault log data.

	Key	Function
6	Status	Shows operational information.
7	Quick Menu	Allows access to programming parameters for initial set-up instructions and many detailed application instructions.
8	Main Menu	Allows access to all programming parameters.
9	Alarm Log	Shows a list of current warnings, the last 10 alarms, and the maintenance log.

Table 5.9 Legend to *Illustration 5.8*, Display Menu Keys

C. Navigation keys and indicator lights (LEDs)

Navigation keys are used for programming functions and moving the display cursor. The navigation keys also provide speed control in local operation. There are also 3 frequency converter status indicator lights in this area.

	Key	Function
10	Back	Reverts to the previous step or list in the menu structure.
11	Cancel	Cancels the last change or command as long as the display mode has not changed.
12	Info	Press for a definition of the function being shown.
13	Navigation keys	To move between items in the menu, use the 4 navigation keys.
14	OK	Press to access parameter groups or to enable a selection.

Table 5.10 Legend to *Illustration 5.8*, Navigation Keys

	Indicator	Light	Function
15	On	Green	ON turns on when the frequency converter receives power from the mains voltage, a DC bus terminal, or a 24 V external supply.
16	Warn	Yellow	When warning conditions are met, the yellow WARN light turns on, and text appears in the display area identifying the problem.
17	Alarm	Red	A fault condition causes the red alarm light to flash, and an alarm text is shown.

Table 5.11 Legend to *Illustration 5.8*, Indicator Lights (LEDs)

D. Operation keys and reset

Operation keys are at the bottom of the LCP.

	Key	Function
18	Hand On	Starts the frequency converter in hand-on mode. <ul style="list-style-type: none"> An external stop signal by control input or serial communication overrides the local hand on.
19	Off	Stops the motor but does not remove power to the frequency converter.
20	Auto On	Puts the system in remote operational mode. <ul style="list-style-type: none"> Responds to an external start command by control terminals or serial communication.
21	Reset	Resets the frequency converter manually after a fault has been cleared.

Table 5.12 Legend to *Illustration 5.8, Operation Keys and Reset***NOTICE**

To adjust the display contrast, press [Status] and the [▲]/[▼] keys.

5.3.6 Parameter Settings

Establishing the correct programming for applications often requires setting functions in several related parameters. Details for parameters are provided in *chapter 10.2 Parameter Menu Structure*.

Programming data is stored internally in the frequency converter.

- For back-up, upload data into the LCP memory.
- To download data to another frequency converter, connect the LCP to that unit and download the stored settings.
- Restoring factory default settings does not change data stored in the LCP memory.

5.3.7 Changing Parameter Settings with GLCP

Access and change parameter settings from the *Quick Menu* or from the *Main Menu*. The *Quick Menu* only gives access to a limited number of parameters.

1. Press [Quick Menu] or [Main Menu] on the LCP.
2. Press [▲] [▼] to browse through the parameter groups, press [OK] to select a parameter group.
3. Press [▲] [▼] to browse through the parameters, press [OK] to select a parameter.
4. Press [▲] [▼] to change the value of a parameter setting.

5. Press [◀] [▶] to shift digit when a decimal parameter is in the editing state.
6. Press [OK] to accept the change.
7. Press either [Back] twice to enter Status, or press [Main Menu] once to enter the Main Menu.

View changes

Quick Menu Q5 - Changes Made lists all parameters changed from default settings.

- The list only shows parameters, which have been changed in the current edit set-up.
- Parameters which have been reset to default values are not listed.
- The message *Empty* indicates that no parameters have been changed.

5.3.8 Uploading/Downloading Data to/from the GLCP

1. Press [Off] to stop the motor before uploading or downloading data.
2. Press [Main Menu] *parameter 0-50 LCP Copy* and press [OK].
3. Select [1] *All to LCP* to upload data to the LCP or select [2] *All from LCP* to download data from the LCP.
4. Press [OK]. A progress bar shows the uploading or downloading progress.
5. Press [Hand On] or [Auto On] to return to normal operation.

5.3.9 Restoring Default Settings with LCP

NOTICE

Risk of losing programming, motor data, localization, and monitoring records by restoration of default settings. To provide a back-up, upload data to the LCP before initialization.

Restoring the default parameter settings is done by initialization of the frequency converter. Initialization is carried out through *parameter 14-22 Operation Mode* (recommended) or manually. Initialization does not reset the settings for *parameter 1-06 Clockwise Direction*.

- Initialization using *parameter 14-22 Operation Mode* does not reset frequency converter settings, such as operating hours, serial communication selections, fault log, alarm log, and other monitoring functions.
- Manual initialization erases all motor, programming, localization, and monitoring data and restores factory default settings.

Recommended initialization procedure, via parameter 14-22 Operation Mode

1. Select *parameter 14-22 Operation Mode* and press [OK].
2. Select *[2] Initialisation* and press [OK].
3. Remove power to the unit and wait until the display turns off.
4. Apply power to the unit.

Default parameter settings are restored during start-up. This may take slightly longer than normal.

5. *Alarm 80, Drive initialised to default value* is shown.
6. Press [Reset] to return to operation mode.

Manual initialization procedure

1. Remove power to the unit and wait until the display turns off.
2. Press and hold [Status], [Main Menu], and [OK] at the same time on the GLCP, or press [Menu] and [OK] at the same time on the NLCP while applying power to the unit (approximately 5 s or until a click is heard and the fan starts).

Factory default parameter settings are restored during start-up. This may take slightly longer than normal.

Manual initialization does not reset the following frequency converter information:

- *Parameter 15-00 Operating hours*
- *Parameter 15-03 Power Up's*
- *Parameter 15-04 Over Temp's*
- *Parameter 15-05 Over Volt's*

5.4 Basic Programming

5.4.1 Asynchronous Motor Set-up

Enter the following motor data in the listed order. Find the information on the motor nameplate.

1. *Parameter 1-20 Motor Power.*
2. *Parameter 1-22 Motor Voltage.*
3. *Parameter 1-23 Motor Frequency.*
4. *Parameter 1-24 Motor Current.*
5. *Parameter 1-25 Motor Nominal Speed.*

For optimum performance in VVC⁺ mode, extra motor data is required to set up the following parameters.

6. *Parameter 1-30 Stator Resistance (Rs).*
7. *Parameter 1-31 Rotor Resistance (Rr).*
8. *Parameter 1-33 Stator Leakage Reactance (X1).*
9. *Parameter 1-35 Main Reactance (Xh).*

The data is found in the motor datasheet (this data is typically not available on the motor nameplate). Run a complete AMA using *parameter 1-29 Automatic Motor Adaption (AMA) [1] Enable Complete AMA* or enter the parameters manually.

Application-specific adjustment when running VVC⁺

VVC⁺ is the most robust control mode. In most situations, it provides optimum performance without further adjustments. Run a complete AMA for best performance.

5.4.2 PM Motor Set-up in VVC⁺

Initial programming steps

1. Set *parameter 1-10 Motor Construction* to the following options to activate PM motor operation:
 - 1a *[1] PM, non salient SPM*
 - 1b *[2] PM, salient IPM, non Sat*
 - 1c *[3] PM, salient IPM, Sat*
2. Select *[0] Open Loop* in *parameter 1-00 Configuration Mode*.

NOTICE

Encoder feedback is not supported for PM motors.

Programming motor data

After selecting 1 of the PM motor options in *parameter 1-10 Motor Construction*, the PM motor-related parameters in *parameter groups 1-2* Motor Data, 1-3* Adv. Motor Data, and 1-4* Adv. Motor Data II* are active. Find the information on the motor nameplate and in the motor datasheet.

Program the following parameters in the listed order:

1. *Parameter 1-24 Motor Current.*
2. *Parameter 1-26 Motor Cont. Rated Torque.*
3. *Parameter 1-25 Motor Nominal Speed.*
4. *Parameter 1-39 Motor Poles.*
5. *Parameter 1-30 Stator Resistance (Rs).*
6. *Parameter 1-37 d-axis Inductance (Ld).*

Enter line-to-common stator winding resistance (Rs). If only line-line data is available, divide the line-line value by 2 to achieve the line-to-common (starpoint) value. It is also possible to measure the value with an ohmmeter, which also takes the resistance of the cable into account. Divide the measured value by 2 and enter the result.

Enter line-to-common direct axis inductance of the PM motor. If only line-to-line data is available, divide the line-line value by 2 to achieve the line-common (starpoint) value.

It is also possible to measure the value with an inductance meter, which also takes the inductance of the cable into account. Divide the measured value by 2 and enter the result.

7. **Parameter 1-40 Back EMF at 1000 RPM.**
Enter line-to-line back EMF of the PM motor at 1000 RPM mechanical speed (RMS value). Back EMF is the voltage generated by a PM motor when no frequency converter is connected and the shaft is turned externally. Back EMF is normally specified for nominal motor speed or for 1000 RPM measured between 2 lines. If the value is not available for a motor speed of 1000 RPM, calculate the correct value as follows: For example, if back EMF at 1800 RPM is 320 V, the back EMF at 1000 RPM is:
Back EMF=(Voltage/RPM)x1000=(320/1800)x1000=178.
Program this value for *parameter 1-40 Back EMF at 1000 RPM*.

Test motor operation

1. Start the motor at low speed (100–200 RPM). If the motor does not turn, check installation, general programming, and motor data.

Parking

This function is the recommended choice for applications where the motor rotates at slow speed (for example, windmilling in fan applications). *Parameter 2-06 Parking Current* and *parameter 2-07 Parking Time* are adjustable. Increase the factory setting of these parameters for applications with high inertia.

Start the motor at nominal speed. If the application does not run well, check the VVC+ PM settings. *Table 5.13* shows recommendations in different applications.

Application	Settings
Low inertia applications $I_{Load}/I_{Motor} < 5$	<ul style="list-style-type: none"> • Increase the value for <i>parameter 1-17 Voltage filter time const.</i> by factor 5–10. • Reduce the value for <i>parameter 1-14 Damping Gain</i>. • Reduce the value (<100%) for <i>parameter 1-66 Min. Current at Low Speed</i>.
Medium inertia applications $50 > I_{Load}/I_{Motor} > 5$	Keep calculated values.
High inertia applications $I_{Load}/I_{Motor} > 50$	Increase the values for <i>parameter 1-14 Damping Gain</i> , <i>parameter 1-15 Low Speed Filter Time Const.</i> , and <i>parameter 1-16 High Speed Filter Time Const.</i>
High load at low speed <30% (rated speed)	Increase the value for <i>parameter 1-17 Voltage filter time const.</i> Increase the value for <i>parameter 1-66 Min. Current at Low Speed</i> (>100% for longer time can overheat the motor).

Table 5.13 Recommendations in Different Applications

If the motor starts oscillating at a certain speed, increase *parameter 1-14 Damping Gain*. Increase the value in small steps.

Starting torque can be adjusted in *parameter 1-66 Min. Current at Low Speed*. 100% provides nominal torque as starting torque.

5.4.3 Automatic Motor Adaptation (AMA)

To optimize compatibility between the frequency converter and the motor in VVC+ mode, run AMA.

- The frequency converter builds a mathematical model of the motor for regulating output motor current, thus enhancing motor performance.
- Some motors may be unable to run the complete version of the test. In that case, select [2] *Enable reduced AMA* in *parameter 1-29 Automatic Motor Adaption (AMA)*.
- If warnings or alarms occur, see *chapter 8.4 List of Warnings and Alarms*.
- For best results, run this procedure on a cold motor.

To run AMA using the LCP

1. By default parameter setting, connect terminals 13 and 27 before running AMA.
2. Enter the *Main Menu*.
3. Go to *parameter group 1-** Load and Motor*.
4. Press [OK].
5. Set motor parameters using nameplate data for *parameter group 1-2* Motor Data*.
6. Set motor cable length in *parameter 1-42 Motor Cable Length*.
7. Go to *parameter 1-29 Automatic Motor Adaption (AMA)*.
8. Press [OK].
9. Select [1] *Enable complete AMA*.
10. Press [OK].
11. The test runs automatically and indicates when it is complete.

Depending on the power size, the AMA takes 3–10 minutes to complete.

NOTICE

The AMA function does not cause the motor to run and it does not harm the motor.

5.5 Checking Motor Rotation

Before running the frequency converter, check the motor rotation.

1. Press [Hand On].
2. Press [▲] for positive speed reference.
3. Check that the speed shown is positive.
4. Verify that the wiring between the frequency converter and the motor is correct.
5. Verify that the motor running direction matches the setting in *parameter 1-06 Clockwise Direction*.
 - 5a When *parameter 1-06 Clockwise Direction* is set to [0] *Normal* (default clockwise):
 - a. Verify that the motor turns clockwise.
 - b. Verify that the LCP direction arrow is clockwise.
 - 5b When *parameter 1-06 Clockwise Direction* is set to [1] *Inverse* (counterclockwise):
 - a. Verify that the motor turns counterclockwise.
 - b. Verify that the LCP direction arrow is counterclockwise.

5.6 Checking Encoder Rotation

Only check encoder rotation if encoder feedback is used.

1. Select [0] *Open Loop* in *parameter 1-00 Configuration Mode*.
2. Select [1] *24 V encoder* in *parameter 7-00 Speed PID Feedback Source*.
3. Press [Hand On].
4. Press [▲] for positive speed reference (*parameter 1-06 Clockwise Direction* at [0] *Normal*).
5. Check in *parameter 16-57 Feedback [RPM]* that the feedback is positive.

NOTICE**NEGATIVE FEEDBACK**

If the feedback is negative, the encoder connection is wrong. Use *parameter 5-71 Term 32/33 Encoder Direction* to inverse the direction, or reverse the encoder cables.

5.7 Local-control Test

1. Press [Hand On] to provide a local start command to the frequency converter.
2. Accelerate the frequency converter by pressing [▲] to full speed. Moving the cursor left of the decimal point provides quicker input changes.
3. Note any acceleration problems.
4. Press [Off]. Note any deceleration problems.

If acceleration or deceleration problems occur, see *chapter 8.5 Troubleshooting*. See *chapter 8.2 Warning and Alarm Types* for resetting the frequency converter after a trip.

5.8 System Start-up

The procedure in this section requires user-wiring and application programming to be completed. The following procedure is recommended after application set-up is completed.

1. Press [Auto On].
2. Apply an external run command.
3. Adjust the speed reference throughout the speed range.
4. Remove the external run command.
5. Check the sound and vibration levels of the motor to ensure that the system is working as intended.

If warnings or alarms occur, see *chapter 8.2 Warning and Alarm Types* for resetting the frequency converter after a trip.

5.9 STO Commissioning

Refer to *chapter 6 Safe Torque Off (STO)* for the correct installation and commissioning of STO.

6 Safe Torque Off (STO)

The Safe Torque Off (STO) function is a component in a safety control system. STO prevents the unit from generating the energy that is required to rotate the motor, thus ensuring safety in emergency situations.

The STO function is designed and approved suitable for the requirements of:

- IEC/EN 61508: 2010 SIL2
- IEC/EN 61800-5-2: 2007 SIL2
- IEC/EN 62061: 2012 SILCL of SIL2
- EN ISO 13849-1: 2008 Category 3 PL d

To achieve the required level of operational safety, select and apply the components in the safety control system appropriately. Before using STO, carry out a thorough risk analysis on the installation to determine whether the STO function and safety levels are appropriate and sufficient.

The STO function in the frequency converter is controlled via control terminals 37 and 38. When STO is activated, the power supply on the high side and low side of the IGBT gate driving circuits is cut off. *Illustration 6.1* shows the STO architecture. *Table 6.1* shows STO statuses based on whether terminals 37 and 38 are energized.

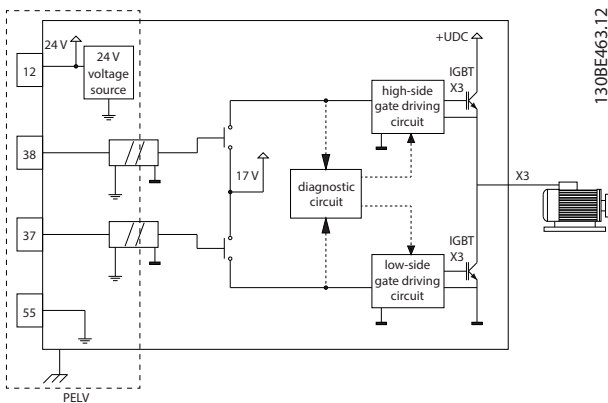

Illustration 6.1 STO Architecture

Terminal 37	Terminal 38	Torque	Warning or alarm
Energized ¹⁾	Energized	Yes ²⁾	No warnings or alarms.
De-energized ³⁾	De-energized	No	Warning/alarm 68: Safe Torque Off.
De-energized	Energized	No	Alarm 188: STO Function Fault.
Energized	De-energized	No	Alarm 188: STO Function Fault.

Table 6.1 STO Status

1) Voltage range is 24 V \pm 5 V, with terminal 55 as the reference terminal.

2) Torque is present only when the frequency converter is operating.

3) Open circuit, or the voltage within the range of 0 V \pm 1.5 V, with terminal 55 as the reference terminal.

Test pulse filtering

For safety devices that generate test pulses on the STO control lines: If the pulse signals stay at low level (\leq 1.8 V) for no longer than 5 ms, they are ignored, as shown in *Illustration 6.2*.

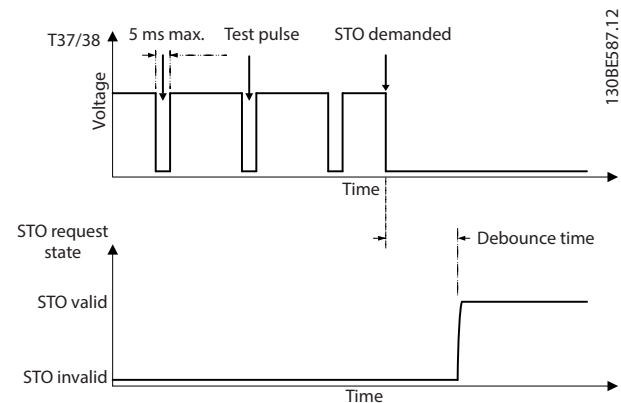

Illustration 6.2 Test Pulse Filtering

Asynchronous input tolerance

The input signals at the 2 terminals are not always synchronous. If the discrepancy between the 2 signals is longer than 12 ms, the STO fault alarm (*alarm 188, STO Function Fault*) occurs.

Valid signals

To activate STO, the 2 signals must both be at low level for at least 80 ms. To terminate STO, the 2 signals must both be at high level for at least 20 ms. Refer to *chapter 9.6 Control Input/Output and Control Data* for the voltage levels and input current of STO terminals.

6.1 Safety Precautions for STO

Qualified personnel

Only qualified personnel are allowed to install or operate this equipment.

Qualified personnel are defined as trained staff, who are authorized to install, commission, and maintain equipment, systems, and circuits in accordance with pertinent laws and regulations. Also, the personnel must be familiar with the instructions and safety measures described in this manual.

NOTICE

After installation of STO, perform a commissioning test as specified in *chapter 6.3.3 STO Commissioning Test*. A passed commissioning test is mandatory after first installation and after each change to the safety installation.

⚠ WARNING

RISK OF ELECTRICAL SHOCK

The STO function does NOT isolate mains voltage to the frequency converter or auxiliary circuits, and therefore does not provide electrical safety. Failure to isolate the mains voltage supply from the unit and wait the time specified could result in death or serious injury.

- Perform work on electrical parts of the frequency converter or the motor only after isolating the mains voltage supply and waiting the time specified in *chapter 2.3.1 Discharge Time*.

NOTICE

When designing the machine application, consider the timing and distance for a coast to stop (STO). For more information regarding stop categories, refer to EN 60204-1.

6.2 Safe Torque Off Installation

For motor connection, AC mains connection, and control wiring, follow the instructions for safe installation in *chapter 4 Electrical Installation*.

Enable the integrated STO as follows:

1. Remove the jumper between control terminals 12 (24 V), 37, and 38. Cutting or breaking the jumper is not sufficient to avoid short-circuiting. See the jumper in *Illustration 6.3*.

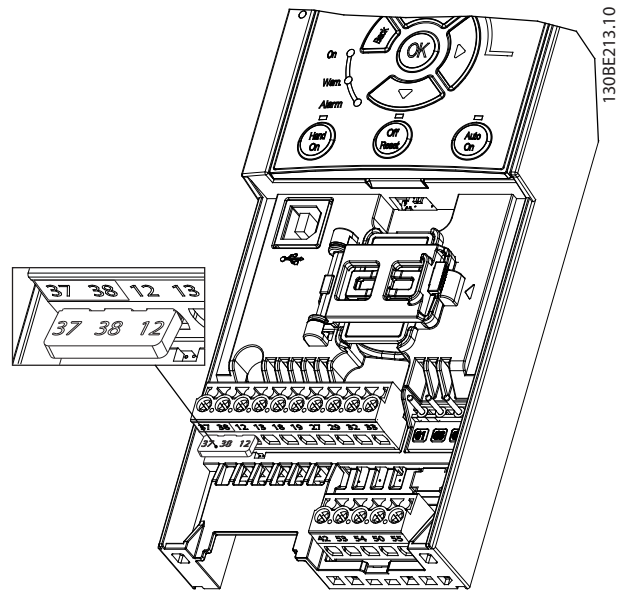
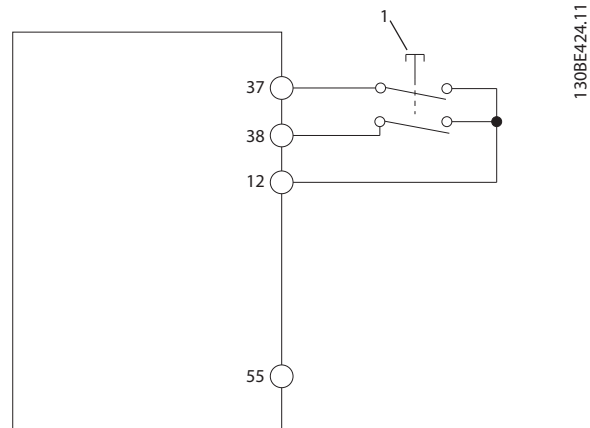

Illustration 6.3 Jumper between Terminal 12 (24 V), 37, and 38

2. Connect a dual-channel safety device (for example safety PLC, light curtain, safety relay, or emergency stop button) to terminals 37 and 38 to form a safety application. The device must comply with the required safety level based on the hazard assessment. *Illustration 6.4* shows the wiring schematic of STO applications where the frequency converter and the safety device are in the same cabinet. *Illustration 6.5* shows the wiring schematic of STO applications where external supply is used.

NOTICE

The STO signal must be PELV supplied.



1	Safety device
---	---------------

Illustration 6.4 STO Wiring in 1 Cabinet, the Frequency Converter Provides the Supply Voltage

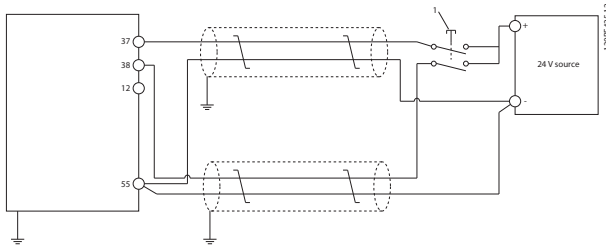

1	Safety device
---	---------------

Illustration 6.5 STO Wiring, External Supply

3. Complete the wiring according to the instructions in *chapter 4 Electrical Installation*, and:
 - 3a Eliminate short circuit risks.
 - 3b Ensure that the STO cables are shielded if they are longer than 20 m (65.6 ft) or outside the cabinet.
 - 3c Connect the safety device directly to terminals 37 and 38.

6.3 STO Commissioning

6.3.1 Activation of Safe Torque Off

To activate the STO function, remove the voltage at terminals 37 and 38 of the frequency converter.

When STO is activated, the frequency converter issues *alarm 68, Safe Torque Off* or *warning 68, Safe Torque Off*, trips the unit, and coasts the motor to stop. Use the STO function to stop the frequency converter in emergency stop situations. In normal operating mode when STO is not required, use the standard stop function instead.

NOTICE

If STO is activated while the frequency converter issues *warning 8, DC undervoltage* or *alarm 8, DC undervoltage*, the frequency converter skips *alarm 68, Safe Torque Off*, but the STO operation is not affected.

6.3.2 Deactivation of Safe Torque Off

Follow the instructions in *Table 6.2* to deactivate the STO function and resume normal operation based on the restart mode of the STO function.

WARNING

RISK OF INJURY OR DEATH

Reapplying 24 V DC supply to either terminal 37 or 38 terminates the SIL2 STO state, potentially starting the motor. Unexpected motor start may cause personal injuries or death.

- Ensure that all safety measures are taken before reapplying 24 V DC supply to terminals 37 and 38.

Restart mode	Steps to deactivate STO and resume normal operation	Restart mode configuration
Manual restart	<ol style="list-style-type: none"> 1. Reapply 24 V DC supply to terminals 37 and 38. 2. Initiate a reset signal (via fieldbus, digital I/O, or [Reset]/[Off Reset] key on the LCP). 	Default setting. <i>Parameter 5-19 Terminal 37/38 Safe Torque Off=[1]</i> <i>Safe Torque Off Alarm</i>
Automatic restart	Reapply 24 V DC supply to terminals 37 and 38.	<i>Parameter 5-19 Terminal 37/38 Safe Torque Off= [3]</i> <i>Safe Torque Off Warning.</i>

Table 6.2 STO Deactivation

6.3.3 STO Commissioning Test

After installation and before first operation, perform a commissioning test of the installation using STO. Perform the test again after each modification of the installation or application involving the STO.

NOTICE

A successful commissioning test of the STO function is required after the initial installation, and after each subsequent change to the installation.

To perform a commissioning test:

- Follow the instructions in *chapter 6.3.4 Test for STO Applications in Manual Restart Mode* if STO is set to manual restart mode.
- Follow the instructions in *chapter 6.3.5 Test for STO Applications in Automatic Restart Mode* if STO is set to automatic restart mode.

6.3.4 Test for STO Applications in Manual Restart Mode

For applications where *parameter 5-19 Terminal 37/38 Safe Torque Off* is set to the default value [1] *Safe Torque Off Alarm*, conduct the commissioning test as follows:

1. Set *parameter 5-40 Function Relay* to [190] *Safe Function active*.
2. Remove the 24 V DC voltage supply to terminals 37 and 38 using the safety device while the frequency converter drives the motor (that is, the mains supply is not interrupted).
3. Verify that:
 - 3a The motor coasts. It may take a long time for the motor to stop.
 - 3b If the LCP is mounted, *alarm 68, Safe Torque Off* shows on the LCP. If the LCP is not mounted, *alarm 68, Safe Torque Off* is logged in *parameter 15-30 Alarm Log: Error Code*.
4. Reapply 24 V DC to terminals 37 and 38.
5. Ensure that the motor remains in the coasted state, and the customer relay (if connected) remains activated.
6. Send reset signal (via fieldbus, digital I/O, or [Reset]/[Off Reset] key on the LCP).
7. Ensure that the motor becomes operational and runs within the original speed range.

The commissioning test is successfully completed when all the above-mentioned steps are passed.

6.3.5 Test for STO Applications in Automatic Restart Mode

For applications where *parameter 5-19 Terminal 37/38 Safe Torque Off* is set to [3] *Safe Torque Off Warning*, conduct the commissioning test as follows:

1. Remove the 24 V DC voltage supply to terminals 37 and 38 by the safety device while the frequency converter drives the motor (that is, the mains supply is not interrupted).
2. Verify that:
 - 2a The motor coasts. It may take a long time for the motor to stop.
 - 2b If the LCP is mounted *Warning 68, Safe Torque Off W68*, shows on the LCP. If the LCP is not mounted, *Warning 68, Safe Torque Off W68* is logged in bit 30 of *parameter 16-92 Warning Word*.
3. Reapply 24 V DC to terminals 37 and 38.

4. Ensure that the motor becomes operational and runs within the original speed range.

The commissioning test is successfully completed when all the above-mentioned steps are passed.

NOTICE

See the warning on the restart behavior in *chapter 6.1 Safety Precautions for STO*.

6.4 Maintenance and Service for STO

- The user is responsible for security measures.
- The frequency converter parameters can be protected with a password.

The functional test consists of 2 parts:

- Basic functional test.
- Diagnostic functional test.

When all the steps are completed successfully, the functional test is successful.

Basic functional test

If the STO function has not been used for 1 year, conduct a basic functional test to detect any failure or malfunction of STO.

1. Ensure that *parameter 5-19 Terminal 37/38 Safe Torque Off* is set to *[1] *Safe Torque Off Alarm*.
2. Remove the 24 V DC voltage supply for terminals 37 and 38.
3. Check if the LCP shows *alarm 68, Safe Torque Off*.
4. Verify that the frequency converter trips the unit.
5. Verify that the motor is coasting and stops completely.
6. Initiate a start signal (via fieldbus, digital I/O, or the LCP), and verify that the motor does not start.
7. Reconnect the 24 V DC voltage supply to terminals 37 and 38.
8. Verify that the motor is not started automatically and restarts only by giving a reset signal (via fieldbus, digital I/O, or [Reset]/[Off Reset] key on the LCP).

Diagnostic functional test

1. Verify that *warning 68, Safe Torque Off* and *alarm 68, Safe Torque Off* do not occur when 24 V supply is connected to terminals 37 and 38.
2. Remove the 24 V supply for terminal 37, and verify that the LCP shows *alarm 188, STO Function Fault* if the LCP is mounted. If the LCP is not mounted, verify that *alarm 188, STO Function Fault* is logged in *parameter 15-30 Alarm Log: Error Code*.

3. Reapply 24 V supply to terminal 37, and verify that resetting the alarm is successful.
4. Remove the 24 V supply for terminal 38 and verify that the LCP shows *alarm 188, STO Function Fault* if the LCP is mounted. If the LCP is not mounted, verify that *alarm 188, STO Function Fault* is logged in *parameter 15-30 Alarm Log: Error Code*.
5. Reapply 24 V supply to terminal 38 and verify that resetting the alarm is successful.

6.5 STO Technical Data

The Failure Modes, Effects, and Diagnostic Analysis (FMEDA) is performed based on the following assumptions:

- VLT® Midi Drive FC 280 takes 10% of the total failure budget for an SIL2 safety loop.
- Failure rates are based on the Siemens SN29500 database.
- Failure rates are constant; wear-out mechanisms are not included.
- For each channel, the safety-related components are considered to be of type A with a hardware fault tolerance of 0.
- The stress levels are average for an industrial environment and the working temperature of components is up to 85 °C (185 °F).
- A safe error (for example output in safe state) is repaired within 8 hours.
- No torque output is the safe state.

6

Safety standards	Safety of Machinery	ISO 13849-1, IEC 62061
	Functional Safety	IEC 61508
Safety function	Safe Torque Off	IEC 61800-5-2
Safety performance	ISO 13849-1	
	Category	Cat. 3
	Diagnostic Coverage (DC)	60% (Low)
	Mean Time to Dangerous Failure (MTTFd)	2400 years (High)
	Performance Level	PL d
	IEC 61508/IEC 61800-5-2/IEC 62061	
	Safety Integrity Level	SIL2
	Probability of Dangerous Failure per Hour (PFH) (High Demand Mode)	7.54E-9 (1/h)
	Probability of Dangerous Failure on Demand (PFD _{avg} for PTI = 20 years) (Low Demand Mode)	6.05E-4
	Safe Failure Fraction (SFF)	For dual-channel parts: >84%
		For single-channel parts: >99%
	Hardware Fault Tolerance (HFT)	For dual-channel parts: HFT = 1
		For single-channel parts: HFT = 0
	Proof Test Interval ²⁾	20 years
Common Cause Failure (CCF)	$\beta = 5\%$; $\beta_D = 5\%$	
Diagnostic Test Interval (DTI)	160 ms	
Systematic Capability	SC 2	
Reaction time ¹⁾	Input to output response time	Enclosure sizes K1–K3: Maximum 50 ms Enclosure sizes K4 and K5: Maximum 30 ms

Table 6.3 Technical Data for STO

1) Reaction time is the amount of time from an input signal condition that triggers the STO until the torque is off on the motor.

2) For proof test procedure, refer to chapter 6.4 Maintenance and Service for STO.

7 Application Examples

7.1 Introduction

The examples in this section are intended as a quick reference for common applications.

- Parameter settings are the regional default values unless otherwise indicated (selected in *parameter 0-03 Regional Settings*).
- Parameters associated with the terminals and their settings are shown next to the drawings.
- Required switch settings for analog terminals 53 or 54 are also shown.

NOTICE

When the STO feature is not used, a jumper wire is required between terminals 12, 37, and 38 for the frequency converter to operate with factory default programming values.

7.2 Application Examples

7.2.1 AMA

		Parameters	
FC		Function	Setting
+24 V	12	Parameter 1-29 Automatic Motor Adaptation (AMA)	[1] Enable complete AMA
+24 V	13		
D IN	18		
D IN	19		
D IN	27		
D IN	29		
D IN	33		
D IN	32	Parameter 5-12 Terminal 27 Digital Input	*[2] Coast inverse
* = Default value			
Notes/comments: Set parameter group 1-2* Motor Data according to motor specifications.			
NOTICE			
If terminal 13 and 27 are not connected, set parameter 5-12 Terminal 27 Digital Input to [0] No operation.			

Table 7.1 AMA with T27 Connected

7.2.2 Speed

		Parameters	
FC		Function	Setting
+24 V	12	Parameter 6-10 Terminal 53 Low Voltage	0.07 V*
+24 V	13		
D IN	18		
D IN	19		
D IN	27		
D IN	29		
D IN	33		
D IN	32	Parameter 6-11 Terminal 53 High Voltage	10 V*
D IN	33	Parameter 6-14 Terminal 53 Low Ref./Feedb. Value	0
+10 V	50	Parameter 6-15 Terminal 53 High Ref./Feedb. Value	50
A IN	53	Parameter 6-19 Terminal 53 mode	[1] Voltage
A IN	54	* = Default value	
COM	55	Notes/comments:	
A OUT	42		

Table 7.2 Analog Speed Reference (Voltage)

		Parameters	
FC		Function	Setting
+24 V	12	Parameter 6-22 Terminal 54 Low Current	4 mA*
+24 V	13		
D IN	18		
D IN	19		
D IN	27		
D IN	29		
D IN	33		
D IN	32	Parameter 6-23 Terminal 54 High Current	20 mA*
D IN	33	Parameter 6-24 Terminal 54 Low Ref./Feedb. Value	0
+10 V	50	Parameter 6-25 Terminal 54 High Ref./Feedb. Value	50
A IN	53	Parameter 6-29 Terminal 54 mode	[0] Current
A IN	54	* = Default value	
COM	55	Notes/comments:	
A OUT	42		

Table 7.3 Analog Speed Reference (Current)

		Parameters	
FC		Function	Setting
+24 V	12	Parameter 6-10 Terminal 53 Low Voltage	0.07 V*
+24 V	13		
D IN	18		
D IN	19		
D IN	27		
D IN	32		
D IN	33	Parameter 6-11 Terminal 53 High Voltage	10 V*
		Parameter 6-14 Terminal 53 Low Ref./Feedb. Value	0
		Parameter 6-15 Terminal 53 High Ref./Feedb. Value	50
		Parameter 6-19 Terminal 53 mode	[1] Voltage
* = Default value			
Notes/comments:			

Table 7.4 Speed Reference (Using a Manual Potentiometer)

		Parameters	
FC		Function	Setting
+24 V	12	Parameter 5-10 Terminal 18 Digital Input	*[8] Start
+24 V	13		
D IN	18		
D IN	19		
D IN	27		
D IN	29		
D IN	32	Parameter 5-12 Terminal 27 Digital Input	[19] Freeze Reference
D IN	33	Parameter 5-13 Terminal 29 Digital Input	[21] Speed Up
		Parameter 5-14 Terminal 32 Digital Input	[22] Speed Down
* = Default value			
Notes/comments:			

Table 7.5 Speed Up/Speed Down

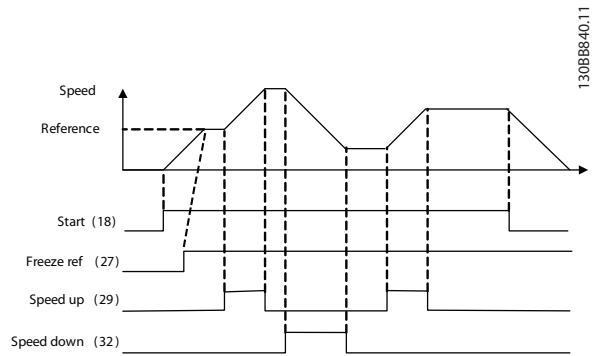

Illustration 7.1 Speed Up/Speed Down

7.2.3 Start/Stop

		Parameters	
FC		Function	Setting
+24 V	12	Parameter 5-10 Terminal 18 Digital Input	[8] Start
+24 V	13		
D IN	18		
D IN	19		
D IN	27		
D IN	29		
D IN	32	Parameter 5-11 Terminal 19 Digital Input	*[10] Reversing
D IN	33	Parameter 5-12 Terminal 27 Digital Input	[0] No operation
		Parameter 5-14 Terminal 32 Digital Input	[16] Preset ref bit 0
		Parameter 5-15 Terminal 33 Digital Input	[17] Preset ref bit 1
Parameter 3-10 Preset Reference			
		Preset ref. 0	25%
		Preset ref. 1	50%
		Preset ref. 2	75%
		Preset ref. 3	100%
* = Default value			
Notes/comments:			

Table 7.6 Start/Stop with Reversing and 4 Preset Speeds

7.2.4 External Alarm Reset

		Parameters	
FC		Function	Setting
+24 V	12	Parameter 5-11 Terminal 19 Digital Input	[1] Reset
+24 V	13		
D IN	18	* = Default value	
D IN	19	Notes/comments:	
D IN	27		
D IN	29		
D IN	32		
D IN	33		
D IN	33		
+10 V	50		
A IN	53		
A IN	54		
COM	55		
A OUT	42		

Table 7.7 External Alarm Reset

7.2.5 Motor Thermistor

NOTICE

To meet PELV insulation requirements, use reinforced or double insulation on the thermistors.

		Parameters	
FC		Function	Setting
+24 V	12	Parameter 1-90 Motor Thermal Protection	[2] Thermistor trip
+24 V	13		
D IN	18	* = Default value	
D IN	19	Parameter 1-93 Thermistor Source	[1] Analog input 53
D IN	27	Parameter 6-19 Terminal 53 mode	[1] Voltage
D IN	29	* = Default value	
D IN	32	Notes/comments: If only a warning is needed, set parameter 1-90 Motor Thermal Protection to [1] Thermistor warning.	
D IN	33		
+10 V	50		
A IN	53		
A IN	54		
COM	55		
A OUT	42		

Table 7.8 Motor Thermistor

7.2.6 SLC

		Parameters	
FC		Function	Setting
+24 V	12	Parameter 4-30 Motor Feedback Loss Function	[1] Warning
+24 V	13		
D IN	18	Parameter 4-31 Motor Feedback Speed Error	50
D IN	19	Parameter 4-32 Motor Feedback Loss Timeout	5 s
D IN	27	Parameter 7-00 Speed PID Feedback Source	[1] 24 V encoder
D IN	29	Parameter 5-70 Term 32/33 Pulses Per Revolution	1024*
D IN	32	Parameter 13-00 SL Controller Mode	[1] On
D IN	33	Parameter 13-01 Start Event	[19] Warning
D IN	33	Parameter 13-02 Stop Event	[44] Reset key
D IN	33	Parameter 13-10 Comparator Operand	[21] Warning no.
D IN	33	Parameter 13-11 Comparator Operator	*[1] ≈
D IN	33	Parameter 13-12 Comparator Value	61
D IN	33	Parameter 13-51 SL Controller Event	[22] Comparator 0
D IN	33	Parameter 13-52 SL Controller Action	[32] Set digital out A low
D IN	33	Parameter 5-40 Function Relay	[80] SL digital output A
		* = Default value	
		Notes/comments: If the limit in the feedback monitor is exceeded, warning 61, feedback monitor is issued. The SLC monitors warning 61, feedback monitor. If warning 61, feedback monitor becomes true, relay 1 is triggered. External equipment could indicate that service is required. If the feedback error goes below the limit again within 5 s, the frequency converter continues, and the warning disappears. Relay 1 persists until [Off/Reset] is pressed.	

Table 7.9 Using SLC to Set a Relay

8 Maintenance, Diagnostics, and Troubleshooting

8.1 Maintenance and Service

Under normal operating conditions and load profiles, the frequency converter is maintenance-free throughout its designed lifetime. To prevent breakdown, danger, and damage, examine the frequency converter at regular intervals depending on the operating conditions. Replace worn or damaged parts with original spare parts or standard parts. For service and support, contact the local Danfoss supplier.

⚠ WARNING

UNINTENDED START

When the frequency converter is connected to AC mains, DC supply, or load sharing, the motor may start at any time. Unintended start during programming, service, or repair work can result in death, serious injury, or property damage. The motor can start with an external switch, a fieldbus command, an input reference signal from the LCP, via remote operation using MCT 10 Set-up Software, or after a cleared fault condition.

To prevent unintended motor start:

- Disconnect the frequency converter from the mains.
- Press [Off/Reset] on the LCP before programming parameters.
- Completely wire and assemble the frequency converter, motor, and any driven equipment before connecting the frequency converter to AC mains, DC supply, or load sharing.

Trip

When tripping, the frequency converter suspends operation to prevent damage to the frequency converter and other equipment. When a trip occurs, the motor coasts to a stop. The frequency converter logic continues to operate and monitor the frequency converter status. After the fault condition is remedied, the frequency converter is ready for a reset.

Trip lock

When trip locking, the frequency converter suspends operation to prevent damage to the frequency converter and other equipment. When a trip lock occurs, the motor coasts to a stop. The frequency converter logic continues to operate and monitor the frequency converter status. The frequency converter starts a trip lock only when serious faults occur that can damage the frequency converter or other equipment. After the faults are fixed, cycle the input power before resetting the frequency converter.

8.3 Warning and Alarm Display

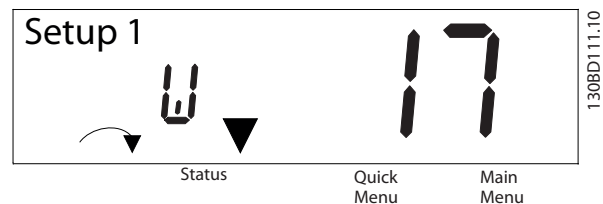

Illustration 8.1 Warning Display

An alarm or trip-lock alarm shows in the display along with the alarm number.

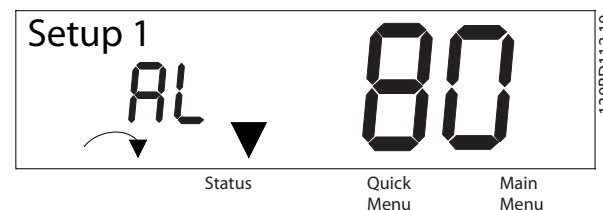

Illustration 8.2 Alarm/Trip Lock Alarm

8.2 Warning and Alarm Types

Warning/ alarm type	Description
Warning	A warning indicates an abnormal operating condition that leads to an alarm. A warning stops when the abnormal condition is removed.
Alarm	An alarm indicates a fault that requires immediate attention. The fault always triggers a trip or trip lock. Reset the frequency converter after an alarm. Reset the frequency converter in any of 4 ways: <ul style="list-style-type: none"> • Press [Reset]/[Off/Reset]. • Digital reset input command. • Serial communication reset input command. • Auto reset.

In addition to the text and alarm code on the frequency converter display, there are 3 status indicator lights. The warning indicator light is yellow during a warning. The alarm indicator light is red and flashing during an alarm.

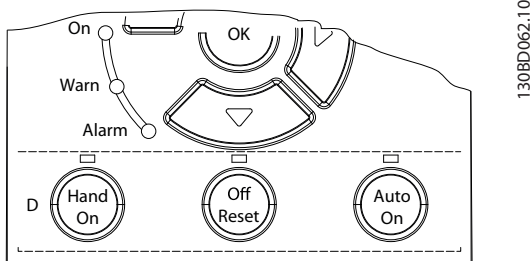

Illustration 8.3 Status Indicator Lights

8.4 List of Warnings and Alarms

8.4.1 Warning and Alarm Code List

An (X) marked in *Table 8.1* indicates that the warning or alarm has occurred.

No.	Description	Warning	Alarm	Trip lock	Cause
2	Live zero error	X	X	–	The signal on terminal 53 or 54 is less than 50% of value set in <i>parameter 6-10 Terminal 53 Low Voltage</i> , <i>parameter 6-20 Terminal 54 Low Voltage</i> , and <i>parameter 6-22 Terminal 54 Low Current</i> .
3	No motor	X	–	–	No motor has been connected to the output of the frequency converter.
4	Mains phase loss ¹⁾	X	X	X	Missing phase on the supply side, or the voltage imbalance is too high. Check the supply voltage.
7	DC overvoltage ¹⁾	X	X	–	DC-link voltage exceeds limit.
8	DC undervoltage ¹⁾	X	X	–	DC-link voltage drops below the voltage warning low limit.
9	Inverter overloaded	X	X	–	More than 100% load for too long.
10	Motor ETR overtemperature	X	X	–	Motor is too hot due to more than 100% load for too long.
11	Motor thermistor overtemperature	X	X	–	Thermistor or thermistor connection is disconnected, or the motor is too hot.
12	Torque limit	X	X	–	Torque exceeds value set in either <i>parameter 4-16 Torque Limit Motor Mode</i> or <i>parameter 4-17 Torque Limit Generator Mode</i> .
13	Overcurrent	X	X	X	Inverter peak current limit is exceeded. If this alarm occurs on power-up, check whether power cables are mistakenly connected to the motor terminals.
14	Ground fault	–	X	X	Discharge from output phases to ground.
16	Short circuit	–	X	X	Short circuit in motor or on motor terminals.
17	Control word timeout	X	X	–	No communication to frequency converter.
25	Brake resistor short-circuited	–	X	X	Brake resistor is short-circuited, thus the brake function is disconnected.
26	Brake overload	X	X	–	The power transmitted to the brake resistor over the last 120 s exceeds the limit. Possible corrections: Decrease brake energy via lower speed or longer ramp time.
27	Brake IGBT/Brake chopper short-circuited	–	X	X	Brake transistor is short-circuited, thus the brake function is disconnected.
28	Brake check	–	X	–	Brake resistor is not connected/working.
30	U phase loss	–	X	X	Motor phase U is missing. Check the phase.
31	V phase loss	–	X	X	Motor phase V is missing. Check the phase.
32	W phase loss	–	X	X	Motor phase W is missing. Check the phase.
34	Fieldbus fault	X	X	–	PROFIBUS communication issues have occurred.
35	Option fault	–	X	–	Fieldbus detects internal faults.
36	Mains failure	X	X	–	This warning/alarm is only active if the supply voltage to the frequency converter is less than the value set in <i>parameter 14-11 Mains Voltage at Mains Fault</i> , and <i>parameter 14-10 Mains Failure</i> is NOT set to [0] No Function.
38	Internal fault	–	X	X	Contact the local Danfoss supplier.
40	Overload T27	X	–	–	Check the load connected to terminal 27 or remove short-circuit connection.
46	Gate drive voltage fault	–	X	X	–
47	24 V supply low	X	X	X	24 V DC may be overloaded.

No.	Description	Warning	Alarm	Trip lock	Cause
49	Speed limit	-	X	-	The motor speed is below the specified limit in <i>parameter 1-87 Trip Speed Low [Hz]</i> .
50	AMA calibration failed	-	X	-	A calibration error has occurred.
51	AMA check U_{nom} and I_{nom}	-	X	-	Wrong setting for motor voltage and/or motor current.
52	AMA low I_{nom}	-	X	-	Motor current is too low. Check the settings.
53	AMA big motor	-	X	-	The power size of the motor is too large for the AMA to operate.
54	AMA small motor	-	X	-	The power size of the motor is too small for the AMA to operate.
55	AMA parameter range	-	X	-	The parameter values of the motor are outside of the acceptable range. AMA does not run.
56	AMA interrupt	-	X	-	The AMA is interrupted.
57	AMA timeout	-	X	-	-
58	AMA internal	-	X	-	Contact Danfoss.
59	Current limit	X	X	-	Frequency converter overload.
60	External interlock	-	X	-	External interlock has been activated.
61	Encoder loss	X	X	-	-
63	Mechanical brake low	-	X	-	The actual motor current has not exceeded the release brake current within the start delay time window.
65	Control card temp	X	X	X	The cutout temperature of the control card has exceeded the upper limit.
67	Option change	-	X	-	A new option is detected or a mounted option is removed.
68	Safe Torque Off ²⁾	X	X	-	STO is activated. If STO is in manual restart mode (default), to resume normal operation, apply 24 V DC to terminals 37 and 38, and initiate a reset signal (via fieldbus, digital I/O, or [Reset]/[Off Reset] key). If STO is in automatic restart mode, applying 24 V DC to terminals 37 and 38 automatically resumes the frequency converter to normal operation.
69	Power card temp	X	X	X	The cutout temperature of the power card has exceeded the upper limit.
80	Drive initialized to default value	-	X	-	All parameter settings are initialized to default settings.
87	Auto DC braking	X	-	-	Occurs in IT mains when the frequency converter coasts, and the DC voltage is higher than 830 V for 400 V units and 425 V for 200 V units. The motor consumes energy on the DC link. This function can be enabled/disabled in <i>parameter 0-07 Auto DC Braking</i> .
88	Option detection	-	X	X	The option is removed successfully.
95	Broken belt	X	X	-	-
99	Locked rotor	-	X	-	Rotor is blocked.
120	Position control fault	-	X	-	-
126	Motor rotating	-	X	-	PM motor is rotating when execute AMA.
127	Back EMF too high	X	-	-	The back EMF of PM motor is too high before starting.
188	STO internal fault ²⁾	-	X	-	24 V DC supply is connected to only 1 of the 2 STO terminals (37 and 38), or a failure in STO channels is detected. Ensure that both terminals are powered by 24 V DC supply, and that the discrepancy between the signals at the 2 terminals is less than 12 ms. If the fault still occurs, contact the local Danfoss supplier.
nw run	Not while running	-	-	-	Parameters can only be changed when the motor is stopped.

No.	Description	Warning	Alarm	Trip lock	Cause
Err.	A wrong password was entered	-	-	-	Occurs when using a wrong password for changing a password-protected parameter.

Table 8.1 Warnings and Alarms Code List

- 1) Mains distortions may cause these faults. Installing a Danfoss line filter may rectify this problem.
 2) This alarm cannot be reset via parameter 14-20 Reset Mode automatically.

For diagnosis, read out the alarm words, warning words, and extended status words.

Bit	Hex	Dec	Alarm word (parameter 1 6-90 Alarm Word)	Alarm word 2 (parameter 1 6-91 Alarm Word 2)	Alarm word 3 (parameter 1 6-97 Alarm Word 3)	Warning word (parameter 16 -92 Warning Word)	Warning word 2 (parameter 16 -93 Warning Word 2)	Extended status word (parameter 16 -94 Ext. Status Word)	Extended status word 2 (parameter 16-95 Ex t. Status Word 2)
0	000000 01	1	Brake check	Reserved	STO function fault	Reserved	Reserved	Ramping	Off
1	000000 02	2	Pwr. card temp	Gate drive voltage fault	MM alarm	Pwr. card temp	Reserved	AMA tuning	Hand/Auto
2	000000 04	4	Earth fault	Reserved	Reserved	Reserved	Reserved	Start CW/CCW	Profibus OFF1 active
3	000000 08	8	Ctrl. card temp	Reserved	Reserved	Ctrl. card temp	Reserved	Slowdown	Profibus OFF2 active
4	000000 10	16	Ctrl. word TO	Reserved	Reserved	Ctrl. word TO	Reserved	Catchup	Profibus OFF3 active
5	000000 20	32	Overcurrent	Reserved	Reserved	Overcurrent	Reserved	Feedback high	Reserved
6	000000 40	64	Torque limit	Reserved	Reserved	Torque limit	Reserved	Feedback low	Reserved
7	000000 80	128	Motor Th. over	Reserved	Reserved	Motor Th. over	Reserved	Output current high	Control ready
8	000001 00	256	Motor ETR over	Broken belt	Reserved	Motor ETR over	Broken belt	Output current low	Frequency converter ready
9	000002 00	512	Inverter overld.	Reserved	Reserved	Inverter overld.	Reserved	Output freq. high	Quick stop
10	000004 00	1024	DC undervolt.	Start failed	Reserved	DC undervolt.	Reserved	Output freq. low	DC brake
11	000008 00	2048	DC overvolt.	Speed limit	Reserved	DC overvolt.	Reserved	Brake check OK	Stop
12	000010 00	4096	Short circuit	External interlock	Reserved	Reserved	Reserved	Braking max	Reserved
13	000020 00	8192	Reserved	Reserved	Reserved	Reserved	Reserved	Braking	Freeze output request
14	000040 00	16384	Mains ph. loss	Reserved	Reserved	Mains ph. loss	Reserved	Reserved	Freeze output
15	000080 00	32768	AMA not OK	Reserved	Reserved	No motor	Auto DC braking	OVC active	Jog request
16	000100 00	65536	Live zero error	Reserved	Reserved	Live zero error	Reserved	AC brake	Jog
17	000200 00	131072	Internal fault	Reserved	Reserved	Reserved	Reserved	Reserved	Start request

Bit	Hex	Dec	Alarm word (parameter 1 6-90 Alarm Word)	Alarm word 2 (parameter 1 6-91 Alarm Word 2)	Alarm word 3 (parameter 1 6-97 Alarm Word 3)	Warning word (parameter 16 -92 Warning Word)	Warning word 2 (parameter 16 -93 Warning Word 2)	Extended status word (parameter 16 -94 Ext. Status Word)	Extended status word 2 (parameter 16-95 Ex t. Status Word 2)
18	000400 00	262144	Brake overload	Reserved	Reserved	Brake resistor power limit	Reserved	Reserved	Start
19	000800 00	524288	U phase loss	Reserved	Reserved	Reserved	Reserved	Reference high	Reserved
20	001000 00	1048576	V phase loss	Option detection	Reserved	Reserved	Overload T27	Reference low	Start delay
21	002000 00	2097152	W phase loss	Option fault	Reserved	Reserved	Reserved	Reserved	Sleep
22	004000 00	4194304	Fieldbus fault	Locked rotor	Reserved	Fieldbus fault	Memory module	Reserved	Sleep boost
23	008000 00	8388608	24 V supply low	Position ctrl. fault	Reserved	24 V supply low	Reserved	Reserved	Running
24	010000 00	16777216	Mains failure	Reserved	Reserved	Mains failure	Reserved	Reserved	Bypass
25	020000 00	33554432	Reserved	Current limit	Reserved	Current limit	Reserved	Reserved	Reserved
26	040000 00	67108864	Brake resistor	Reserved	Reserved	Reserved	Reserved	Reserved	External interlock
27	080000 00	134217728	Brake IGBT	Reserved	Reserved	Reserved	Reserved	Reserved	Reserved
28	100000 00	268435456	Option change	Reserved	Reserved	Encoder loss	Reserved	Reserved	FlyStart active
29	200000 00	536870912	Frequency converter initialized	Encoder loss	Reserved	Reserved	Back EMF too high	Reserved	Heat sink clean warning
30	400000 00	1073741824	Safe Torque Off	Reserved	Reserved	Safe Torque Off	Reserved	Reserved	Reserved
31	800000 00	2147483648	Mech. brake low	Reserved	Reserved	Reserved	Reserved	Database busy	Reserved

Table 8.2 Description of Alarm Word, Warning Word, and Extended Status Word

8.5 Troubleshooting

Symptom	Possible cause	Test	Solution
Motor not running	LCP stop	Check if [Off] has been pressed.	Press [Auto On] or [Hand On] (depending on operating mode) to run the motor.
	Missing start signal (standby)	Check <i>parameter 5-10 Terminal 18 Digital Input</i> of correct setting for terminal 18 (use default setting).	Apply a valid start signal to start the motor.
	Motor coast signal active (coasting)	Check <i>parameter 5-12 Terminal 27 Digital Input</i> for correct setting of terminal 27 (use default setting).	Apply 24 V on terminal 27 or program this terminal to [0] <i>No operation</i> .
	Wrong reference signal source	Check the following: <ul style="list-style-type: none"> • The reference signal is local, remote, or bus reference? • Preset reference is active? • Terminal connection is correct? • The scaling of terminals is correct? • The reference signal is available? 	Program correct settings. Set preset reference active in <i>parameter group 3-1* References</i> . Check for correct wiring. Check scaling of terminals. Check reference signal.
Motor is running in the wrong direction	Motor rotation limit	Check that <i>parameter 4-10 Motor Speed Direction</i> is programmed correctly.	Program correct settings.
	Active reversing signal	Check if a reversing command is programmed for the terminal in <i>parameter group 5-1* Digital inputs</i> .	Deactivate reversing signal.
	Wrong motor phase connection	Change <i>parameter 1-06 Clockwise Direction</i> .	
Motor is not reaching maximum speed	Frequency limits are set incorrectly	Check output limits in <i>parameter 4-14 Motor Speed High Limit [Hz]</i> and <i>parameter 4-19 Max Output Frequency</i> .	Program correct limits.
	Reference input signal not scaled correctly	Check reference input signal scaling in <i>parameter group 6-** Analog I/O mode</i> and <i>parameter group 3-1* References</i> .	Program correct settings.
Motor speed is unstable	Possible incorrect parameter settings	Check the settings of all motor parameters, including all motor compensation settings. For closed-loop operation, check PID settings.	Check settings in <i>parameter group 6-** Analog I/O mode</i> .
Motor runs roughly	Possible overmagnetization	Check for incorrect motor settings in all motor parameters.	Check motor settings in <i>parameter groups 1-2* Motor data, 1-3* Adv motor data, and 1-5* Load indep. setting</i> .
Motor does not brake	Possible incorrect settings in the brake parameters. Possible too short ramp-down times.	Check brake parameters. Check ramp time settings.	Check <i>parameter group 2-0* DC brake</i> and <i>3-0* Reference limits</i> .

Symptom	Possible cause	Test	Solution
Open power fuses or circuit breaker trip	Phase-to-phase short	Motor or panel has a short phase-to-phase. Check motor and panel phase for shorts.	Eliminate any shorts detected.
	Motor overload	Motor is overloaded for the application.	Perform the start-up test and verify that motor current is within specifications. If motor current is exceeding nameplate full load current, the motor may run only with reduced load. Review the specifications for the application.
	Loose connections	Perform pre-start-up check for loose connections.	Tighten loose connections.
Mains current imbalance greater than 3%	Problem with mains power (see <i>alarm 4, Mains phase loss</i> description)	Rotate input power leads into the frequency converter 1 position: A to B, B to C, C to A.	If the imbalanced leg follows the wire, it is a power problem. Check mains supply.
	Problem with the frequency converter unit	Rotate input power leads into the frequency converter 1 position: A to B, B to C, C to A.	If the imbalanced leg stays on same input terminal, it is a problem with the unit. Contact the supplier.
Motor current imbalance greater than 3%	Problem with motor or motor wiring	Rotate output motor leads 1 position: U to V, V to W, W to U.	If the imbalanced leg follows the wire, the problem is in the motor or motor wiring. Check motor and motor wiring.
	Problem with the frequency converter unit	Rotate output motor leads 1 position: U to V, V to W, W to U.	If the imbalanced leg stays on same output terminal, it is a problem with the unit. Contact the supplier.
Acoustic noise or vibration (for example a fan blade is making noise or vibrations at certain frequencies)	Resonances, for example, in the motor/fan system	Bypass critical frequencies by using parameters in <i>parameter group 4-6* Speed Bypass</i> .	Check if noise and/or vibration have been reduced to an acceptable limit.
		Turn off overmodulation in <i>parameter 14-03 Overmodulation</i> .	
		Increase resonance damping in <i>parameter 1-64 Resonance Dampening</i> .	

Table 8.3 Troubleshooting

9 Specifications

9.1 Electrical Data

Frequency converter typical shaft output [kW (hp)]	PK37 0.37 (0.5)	PK55 0.55 (0.74)	PK75 0.75 (1.0)	P1K1 1.1 (1.5)	P1K5 1.5 (2.0)	P2K2 2.2 (3.0)	P3K0 3.0 (4.0)
Enclosure protection rating IP20	K1	K1	K1	K1	K1	K1	K2
Output current							
Shaft output [kW]	0.37	0.55	0.75	1.1	1.5	2.2	3
Continuous (3x380–440 V) [A]	1.2	1.7	2.2	3	3.7	5.3	7.2
Continuous (3x441–480 V) [A]	1.1	1.6	2.1	2.8	3.4	4.8	6.3
Intermittent (60 s overload) [A]	1.9	2.7	3.5	4.8	5.9	8.5	11.5
Continuous kVA (400 V AC) [kVA]	0.9	1.2	1.5	2.1	2.6	3.7	5.0
Continuous kVA (480 V AC) [kVA]	0.9	1.3	1.7	2.5	2.8	4.0	5.2
Maximum input current							
Continuous (3x380–440 V) [A]	1.2	1.6	2.1	2.6	3.5	4.7	6.3
Continuous (3x441–480 V) [A]	1.0	1.2	1.8	2.0	2.9	3.9	4.3
Intermittent (60 s overload) [A]	1.9	2.6	3.4	4.2	5.6	7.5	10.1
More specifications							
Maximum cable cross-section (mains, motor, brake, and load sharing) [mm ² (AWG)]	4 (12)						
Estimated power loss at rated maximum load [W] ¹⁾	20.9	25.2	30	40	52.9	74	94.8
Weight, enclosure protection rating IP20 [kg (lb)]	2.3 (5.1)	2.3 (5.1)	2.3 (5.1)	2.3 (5.1)	2.3 (5.1)	2.5 (5.5)	3.6 (7.9)
Efficiency [%] ²⁾	96.0	96.6	96.8	97.2	97.0	97.5	98.0

Table 9.1 Mains Supply 3x380–480 V AC

Frequency converter typical shaft output [kW (hp)]	P4K0 4 (5.4)	P5K5 5.5 (7.4)	P7K5 7.5 (10)	P11K 11 (15)	P15K 15 (20)	P18K 18.5 (25)	P22K 22 (30)
Enclosure protection rating IP20	K2	K2	K3	K4	K4	K5	K5
Output current							
Shaft output	4	5.5	7.5	11	15	18.5	22
Continuous (3x380–440 V) [A]	9	12	15.5	23	31	37	42.5
Continuous (3x441–480 V) [A]	8.2	11	14	21	27	34	40
Intermittent (60 s overload) [A]	14.4	19.2	24.8	34.5	46.5	55.5	63.8
Continuous kVA (400 V AC) [kVA]	6.2	8.3	10.7	15.9	21.5	25.6	29.5
Continuous kVA (480 V AC) [kVA]	6.8	9.1	11.6	17.5	22.4	28.3	33.3
Maximum input current							
Continuous (3x380–440 V) [A]	8.3	11.2	15.1	22.1	29.9	35.2	41.5
Continuous (3x441–480 V) [A]	6.8	9.4	12.6	18.4	24.7	29.3	34.6
Intermittent (60 s overload) [A]	13.3	17.9	24.2	33.2	44.9	52.8	62.3
More specifications							
Maximum cable size (mains, motor, brake) [mm ² (AWG)]	4 (12)			16 (6)			
Estimated power loss at rated maximum load [W] ¹⁾	115.5	157.5	192.8	289.5	393.4	402.8	467.5
Weight enclosure protection rating IP20 [kg (lb)]	3.6 (7.9)	3.6 (7.9)	4.1 (9.0)	9.4 (20.7)	9.5 (20.9)	12.3 (27.1)	12.5 (27.6)
Efficiency [%] ²⁾	98.0	97.8	97.7	98.0	98.1	98.0	98.0

Table 9.2 Mains Supply 3x380–480 V AC

Frequency converter typical shaft output [kW (hp)]	PK37 0.37 (0.5)	PK55 0.55 (0.74)	PK75 0.75 (1.0)	P1K1 1.1 (1.5)	P1K5 1.5 (2.0)	P2K2 2.2 (3.0)	P3K7 3.7 (5.0)
Enclosure protection rating IP20	K1	K1	K1	K1	K1	K2	K3
Output current							
Continuous (3x200–240 V) [A]	2.2	3.2	4.2	6	6.8	9.6	15.2
Intermittent (60 s overload) [A]	3.5	5.1	6.7	9.6	10.9	15.4	24.3
Continuous kVA (230 V AC) [kVA]	0.9	1.3	1.7	2.4	2.7	3.8	6.1
Maximum input current							
Continuous (3x200–240 V) [A]	1.8	2.7	3.4	4.7	6.3	8.8	14.3
Intermittent (60 s overload) [A]	2.9	4.3	5.4	7.5	10.1	14.1	22.9
More specifications							
Maximum cable size (mains, motor, brake) [mm ² (AWG)]	4 (12)						
Estimated power loss at rated maximum load [W] ¹⁾	29.4	38.5	51.1	60.7	76.1	96.1	147.5
Weight enclosure protection rating IP20 [kg (lb)]	2.3 (5.1)	2.3 (5.1)	2.3 (5.1)	2.3 (5.1)	2.3 (5.1)	2.5 (5.5)	3.6 (7.9)
Efficiency [%] ²⁾	96.4	96.6	96.3	96.6	96.5	96.7	96.7

Table 9.3 Mains Supply 3x200–240 V AC

Frequency converter typical shaft output [kW (hp)]	PK37 0.37 (0.5)	PK55 0.55 (0.74)	PK75 0.75 (1.0)	P1K1 1.1 (1.5)	P1K5 1.5 (2.0)	P2K2 2.2 (3.0)
Enclosure protection rating IP20	K1	K1	K1	K1	K1	K2
Output current						
Continuous (1x200–240 V) [A]	2.2	3.2	4.2	6	6.8	9.6
Intermittent (60 s overload) [A]	3.5	5.1	6.7	9.6	10.9	15.4
Continuous kVA (230 V AC) [kVA]	0.9	1.3	1.7	2.4	2.7	3.8
Maximum input current						
Continuous (1x200–240 V) [A]	2.9	4.4	5.5	7.7	10.4	14.4
Intermittent (60 s overload) [A]	4.6	7.0	8.8	12.3	16.6	23.0
More specifications						
Maximum cable size (mains, motor, brake) [mm ² (AWG)]	4 (12)					
Estimated power loss at rated maximum load [W] ¹⁾	37.7	46.2	56.2	76.8	97.5	121.6
Weight enclosure protection rating IP20 [kg (lb)]	2.3 (5.1)	2.3 (5.1)	2.3 (5.1)	2.3 (5.1)	2.3 (5.1)	2.5 (5.5)
Efficiency [%] ²⁾	94.4	95.1	95.1	95.3	95.0	95.4

Table 9.4 Mains Supply 1x200–240 V AC

1) The typical power loss is at nominal load conditions and expected to be within $\pm 15\%$ (tolerance relates to variety in voltage and cable conditions).

Values are based on a typical motor efficiency (IE2/IE3 border line). Motors with lower efficiency add to the power loss in the frequency converter, and motors with high efficiency reduce power loss.

Applies to dimensioning of frequency converter cooling. If the switching frequency is higher than the default setting, the power losses sometimes rise. LCP and typical control card power consumptions are included. Further options and customer load sometimes add up to 30 W to the losses (though typically only 4 W extra for a fully loaded control card or fieldbus).

For power loss data according to EN 50598-2, refer to www.danfoss.com/vltenergyefficiency.

2) Measured using 50 m (164 ft) shielded motor cables at rated load and rated frequency. For energy efficiency class, see chapter 9.4 Ambient Conditions. For part load losses, see www.danfoss.com/vltenergyefficiency.

9.2 Mains Supply

Mains supply (L1/N, L2/L, L3)

Supply terminals	(L1/N, L2/L, L3)
Supply voltage	380–480 V: -15% (-25%) ¹⁾ to +10%
Supply voltage	200–240 V: -15% (-25%) ¹⁾ to +10%
<p>1) The frequency converter can run at -25% input voltage with reduced performance. The maximum output power of the frequency converter is 75% if input voltage is -25%, and 85% if input voltage is -15%. Full torque cannot be expected at mains voltage lower than 10% below the lowest rated supply voltage of the frequency converter.</p>	
Supply frequency	50/60 Hz ±5%
Maximum imbalance temporary between mains phases	3.0% of rated supply voltage
True power factor (λ)	≥0.9 nominal at rated load
Displacement power factor ($\cos \phi$)	Near unity (>0.98)
Switching on input supply (L1/N, L2/L, L3) (power-ups) ≤7.5 kW (10 hp)	Maximum 2 times/minute
Switching on input supply (L1/N, L2/L, L3) (power-ups) 11–22 kW (15–30 hp)	Maximum 1 time/minute

9.3 Motor Output and Motor Data

Motor output (U, V, W)

Output voltage	0–100% of supply voltage
Output frequency	0–500 Hz
Output frequency in VVC ⁺ mode	0–200 Hz
Switching on output	Unlimited
Ramp time	0.01–3600 s
Torque characteristics	
Starting torque (constant torque)	Maximum 160% for 60 s ¹⁾
Overload torque (constant torque)	Maximum 160% for 60 s ¹⁾
Starting current	Maximum 200% for 1 s
Torque rise time in VVC ⁺ mode (independent of f_{sw})	Maximum 50 ms

1) Percentage relates to the nominal torque. It is 150% for 11–22 kW (15–30 hp) frequency converters.

9.4 Ambient Conditions

Ambient conditions

Enclosure protection rating, frequency converter	IP20
Enclosure protection rating, conversion kit	IP21/Type 1
Vibration test, all enclosure sizes	1.14 g
Relative humidity	5–95% (IEC 721-3-3; Class 3K3 (non-condensing) during operation)
Ambient temperature (at DPWM switching mode)	
- with derating	Maximum 55 °C (131 °F) ¹⁾²⁾³⁾
- at full constant output current	Maximum 45 °C (113 °F) ⁴⁾
Minimum ambient temperature during full-scale operation	0 °C (32 °F)
Minimum ambient temperature at reduced performance	-10 °C (14 °F)
Temperature during storage/transport	-25 to +65/70 °C (-13 to +149/158 °F)
Maximum altitude above sea level without derating	1000 m (3280 ft)
Maximum altitude above sea level with derating	3000 m (9243 ft)
EMC standards, emission	EN 61800-3, EN 61000-3-2, EN 61000-3-3, EN 61000-3-11, EN 61000-3-12, EN 61000-6-3/4, EN 55011, IEC 61800-3
EMC standards, immunity	EN 61800-3, EN 61000-6-1/2, EN 61000-4-2, EN 61000-4-3 EN 61000-4-4, EN 61000-4-5, EN 61000-4-6, EN 61326-3-1
Energy efficiency class ⁵⁾	IE2

1) Refer to Special Conditions in the design guide for:

- Derating for high ambient temperature.
- Derating for high altitude.

2) For PROFIBUS, PROFINET, and EtherNet/IP variant of VLT[®] Midi Drive FC 280, to prevent control card overtemperature, avoid full digital/analog I/O load at ambient temperature higher than 45 °C (113 °F).

3) Ambient temperature for K1S2 with derating is maximum 50 °C (122 °F).

4) Ambient temperature for K1S2 at full constant output current is maximum 40 °C (104 °F).

5) Determined according to EN 50598-2 at:

- Rated load.
- 90% rated frequency.
- Switching frequency factory setting.
- Switching pattern factory setting.
- Open type: Surrounding air temperature 45 °C (113 °F).
- Type 1 (NEMA kit): Ambient temperature 45 °C (113 °F).

9.5 Cable Specifications

Cable lengths and cross-sections¹⁾

Maximum motor cable length, shielded	50 m (164 ft)
Maximum motor cable length, unshielded	75 m (246 ft)
Maximum cross-section of control terminals, flexible/rigid wire	2.5 mm ² /14 AWG
Minimum cross-section of control terminals	0.55 mm ² /30 AWG
Maximum STO input cable length, unshielded	20 m (66 ft)

1) For power cables, see Table 9.1, Table 9.2, Table 9.3 and Table 9.4.

9.6 Control Input/Output and Control Data

Digital inputs

Terminal number	18, 19, 27 ¹⁾ , 29, 32, 33
Logic	PNP or NPN
Voltage level	0–24 V DC
Voltage level, logic 0 PNP	<5 V DC
Voltage level, logic 1 PNP	>10 V DC
Voltage level, logic 0 NPN	>19 V DC
Voltage level, logic 1 NPN	<14 V DC
Maximum voltage on input	28 V DC
Pulse frequency range	4–32 kHz
(Duty cycle) minimum pulse width	4.5 ms
Input resistance, R _i	Approximately 4 kΩ

1) Terminal 27 can also be programmed as output.

STO inputs¹⁾

Terminal number	37, 38
Voltage level	0–30 V DC
Voltage level, low	<1.8 V DC
Voltage level, high	>20 V DC
Maximum voltage on input	30 V DC
Minimum input current (each pin)	6 mA

1) Refer to chapter 6 Safe Torque Off (STO) for more details about STO inputs.

Analog inputs

Number of analog inputs	2
Terminal number	53 ¹⁾ , 54
Modes	Voltage or current
Mode select	Software
Voltage level	0–10 V
Input resistance, R _i	Approximately 10 kΩ
Maximum voltage	-15 V to +20 V
Current level	0/4 to 20 mA (scaleable)
Input resistance, R _i	Approximately 200 Ω
Maximum current	30 mA
Resolution for analog inputs	11 bit
Accuracy of analog inputs	Maximum error 0.5% of full scale
Bandwidth	100 Hz

The analog inputs are galvanically isolated from the supply voltage (PELV) and other high-voltage terminals.

1) Terminal 53 supports only voltage mode and can also be used as digital input.

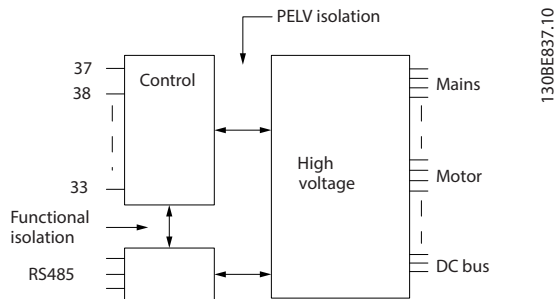

Illustration 9.1 Galvanic Isolation

NOTICE

HIGH ALTITUDE

For installation at altitudes above 2000 m (6562 ft), contact Danfoss hotline regarding PELV.

Pulse inputs

Programmable pulse inputs	2
Terminal number pulse	29, 33
Maximum frequency at terminal 29, 33	32 kHz (push-pull driven)
Maximum frequency at terminal 29, 33	5 kHz (open collector)
Minimum frequency at terminal 29, 33	4 Hz
Voltage level	See the section on digital input
Maximum voltage on input	28 V DC
Input resistance, R _i	Approximately 4 kΩ
Pulse input accuracy	Maximum error: 0.1% of full scale

Digital outputs

Programmable digital/pulse outputs	1
Terminal number	27 ¹⁾
Voltage level at digital/frequency output	0–24 V
Maximum output current (sink or source)	40 mA
Maximum load at frequency output	1 kΩ
Maximum capacitive load at frequency output	10 nF
Minimum output frequency at frequency output	4 Hz
Maximum output frequency at frequency output	32 kHz
Accuracy of frequency output	Maximum error: 0.1% of full scale

Resolution of frequency output	10 bit
--------------------------------	--------

1) Terminal 27 can also be programmed as input.

The digital output is galvanically isolated from the supply voltage (PELV) and other high-voltage terminals.

Analog outputs

Number of programmable analog outputs	1
Terminal number	42
Current range at analog output	0/4–20 mA
Maximum resistor load to common at analog output	500 Ω
Accuracy on analog output	Maximum error: 0.8% of full scale
Resolution on analog output	10 bit

The analog output is galvanically isolated from the supply voltage (PELV) and other high-voltage terminals.

Control card, 24 V DC output

Terminal number	12, 13
Maximum load	100 mA

The 24 V DC supply is galvanically isolated from the supply voltage (PELV). However, the supply has the same potential as the analog and digital inputs and outputs.

Control card, +10 V DC output

Terminal number	50
Output voltage	10.5 V ±0.5 V
Maximum load	15 mA

The 10 V DC supply is galvanically isolated from the supply voltage (PELV) and other high-voltage terminals.

Control card, RS485 serial communication

Terminal number	68 (PTX+, RX+), 69 (N, TX-, RX-)
Terminal number 61	Common for terminals 68 and 69

The RS485 serial communication circuit is galvanically isolated from the supply voltage (PELV).

Control card, USB serial communication

USB standard	1.1 (full speed)
USB plug	USB type B plug

Connection to PC is carried out via a standard host/device USB cable.

The USB connection is galvanically isolated from the supply voltage (PELV) and other high-voltage terminals.

The USB ground connection is not galvanically isolated from protective earth. Use only an isolated laptop as PC connection to the USB connector on the frequency converter.

Relay outputs

Programmable relay outputs	1
Relay 01	01–03 (NC), 01–02 (NO)
Maximum terminal load (AC-1) ¹⁾ on 01–02 (NO) (resistive load)	250 V AC, 3 A
Maximum terminal load (AC-15) ¹⁾ on 01–02 (NO) (inductive load @ cosφ 0.4)	250 V AC, 0.2 A
Maximum terminal load (DC-1) ¹⁾ on 01–02 (NO) (resistive load)	30 V DC, 2 A
Maximum terminal load (DC-13) ¹⁾ on 01–02 (NO) (inductive load)	24 V DC, 0.1 A
Maximum terminal load (AC-1) ¹⁾ on 01–03 (NC) (resistive load)	250 V AC, 3 A
Maximum terminal load (AC-15) ¹⁾ on 01–03 (NC) (inductive load @ cosφ 0.4)	250 V AC, 0.2 A
Maximum terminal load (DC-1) ¹⁾ on 01–03 (NC) (resistive load)	30 V DC, 2 A
Minimum terminal load on 01–03 (NC), 01–02 (NO)	24 V DC 10 mA, 24 V AC 20 mA

1) IEC 60947 parts 4 and 5

The relay contacts are galvanically isolated from the rest of the circuit by reinforced isolation.

Control card performance

Scan interval	1 ms
---------------	------

Control characteristics

Resolution of output frequency at 0–500 Hz	±0.003 Hz
System response time (terminals 18, 19, 27, 29, 32, and 33)	≤2 ms
Speed control range (open loop)	1:100 of synchronous speed
Speed accuracy (open loop)	±0.5% of nominal speed
Speed accuracy (closed loop)	±0.1% of nominal speed

All control characteristics are based on a 4-pole asynchronous motor.

9.7 Connection Tightening Torques

Make sure to use the right torques when tightening all electrical connections. Too low or too high torque sometimes causes electrical connection problems. To ensure that correct torques are applied, use a torque wrench. Recommended slot screwdriver type is SZS 0.6x3.5 mm.

Enclosure type	Power [kW (hp)]	Torque [Nm (in-lb)]					
		Mains	Motor	DC connection	Brake	Ground	Control/relay
K1	0.37–2.2 (0.5–3.0)	0.8 (7.1)	0.8 (7.1)	0.8 (7.1)	0.8 (7.1)	1.6 (14.2)	0.5 (4.4)
K2	3.0–5.5 (4.0–7.5)	0.8 (7.1)	0.8 (7.1)	0.8 (7.1)	0.8 (7.1)	1.6 (14.2)	0.5 (4.4)
K3	7.5 (10)	0.8 (7.1)	0.8 (7.1)	0.8 (7.1)	0.8 (7.1)	1.6 (14.2)	0.5 (4.4)
K4	11–15 (15–20)	1.2 (10.6)	1.2 (10.6)	1.2 (10.6)	1.2 (10.6)	1.6 (14.2)	0.5 (4.4)
K5	18.5–22 (25–30)	1.2 (10.6)	1.2 (10.6)	1.2 (10.6)	1.2 (10.6)	1.6 (14.2)	0.5 (4.4)

Table 9.5 Tightening Torques

9.8 Fuses and Circuit Breakers

Use fuses and/or circuit breakers on the supply side to protect service personnel and equipment from injuries and damage if there is component breakdown inside the frequency converter (first fault).

Branch circuit protection

Protect all branch circuits in an installation (including switch gear and machines) against short circuit and overcurrent according to national/international regulations.

NOTICE

Integral solid-state short-circuit protection does not provide branch circuit protection. Provide branch circuit protection in accordance with the national and local rules and regulations.

Table 9.6 lists the recommended fuses and circuit breakers that have been tested.

CAUTION

PERSONAL INJURY AND EQUIPMENT DAMAGE RISK

Malfunction or failing to follow the recommendations may result in personal risk, and damage to the frequency converter and other equipment.

- Select fuses according to recommendations. Possible damage can be limited to be inside the frequency converter.

NOTICE

EQUIPMENT DAMAGE

Using fuses and/or circuit breakers is mandatory to ensure compliance with IEC 60364 for CE. Failure to follow the protection recommendations can result in damage to the frequency converter.

Danfoss recommends using the fuses and circuit breakers in Table 9.6 to ensure compliance with UL 508C or IEC 61800-5-1. For non-UL applications, design circuit breakers for protection in a circuit capable of delivering a maximum of 50000 A_{rms} (symmetrical), 240 V/400 V maximum. The frequency converter short-circuit current rating (SCCR) is suitable for use on a circuit capable of delivering not more than 100000 A_{rms}, 240 V/480 V maximum when protected by T-Class fuses.

Enclosure size		Power [kW (hp)]	Non-UL fuse	Non-UL circuit breaker (Eaton)	UL fuse (Bussmann, class T)
3-phase 380–480 V	K1	0.37 (0.5)	gG-10	PKZM0-16	JJS-6
		0.55–0.75 (0.74–1.0)			
		1.1–1.5 (1.48–2.0)	gG-20		JJS-10
		2.2 (3.0)			JJS-15
	K2	3.0–5.5 (4.0–7.5)	gG-25	PKZM0-20	JJS-25
	K3	7.5 (10)		PKZM0-25	
	K4	11–15 (15–20)	gG-50	–	JJS-50
K5	18.5–22 (25–30)	gG-80	–	JJS-80	
3-phase 200–240 V	K1	0.37 (0.5)	gG-10	PKZM0-16	JJN-6
		0.55 (0.74)	gG-20		JJN-10
		0.75 (1.0)			JJN-15
		1.1 (1.48)			JJN-20
		1.5 (2.0)			gG-25
	K2	2.2 (3.0)	PKZM0-25		
K3	3.7 (5.0)				
Single-phase 200–240 V	K1	0.37 (0.5)	gG-10	PKZM0-16	JJN-6
		0.55 (0.74)	gG-20		JJN-10
		0.75 (1.0)			JJN-15
		1.1 (1.48)			JJN-20
		1.5 (2.0)			gG-25
	K2	2.2 (3.0)			

Table 9.6 Fuse and Circuit Breaker

9.9 Enclosure Sizes, Power Ratings, and Dimensions

Power size [kW]	Enclosure size	K1					K2			K3	K4		K5		
		0.37	0.55	0.75	1.1	1.5	2.2			–	–	–			
Power size [kW]	Single-phase 200–240 V	0.37	0.55	0.75	1.1	1.5	2.2			–	–	–			
	3-phase 200–240 V	0.37	0.55	0.75	1.1	1.5	2.2			3.7	–	–			
	3-phase 380–480 V	0.37	0.55	0.75	1.1	1.5	2.2	3	4	5.5	7.5	11	15	18.5	22
Dimensions [mm (in)]	FC 280 IP20														
	Height A	210 (8.3)					272.5 (10.7)			272.5 (10.7)	317.5 (12.5)	410 (16.1)			
	Width B	75 (3.0)					90 (3.5)			115 (4.5)	133 (5.2)	150 (5.9)			
	Depth C	168 (6.6)					168 (6.6)			168 (6.6)	245 (9.6)	245 (9.6)			
	FC 280 with IP21 kit														
	Height A	338.5 (13.3)					395 (15.6)			395 (15.6)	425 (16.7)	520 (20.5)			
	Width B	100 (3.9)					115 (4.5)			130 (5.1)	153 (6.0)	170 (6.7)			
	Depth C	183 (7.2)					183 (7.2)			183 (7.2)	260 (10.2)	260 (10.2)			
	FC 280 with NEMA Type 1 kit														
	Height A	294 (11.6)					356 (14)			357 (14.1)	391 (15.4)	486 (19.1)			
	Width B	75 (3.0)					90 (3.5)			115 (4.5)	133 (5.2)	150 (5.9)			
	Depth C	168 (6.6)					168 (6.6)			168 (6.6)	245 (9.6)	245 (9.6)			
Weight [kg (lb)]		2.5 (5.5)					3.6 (7.9)			4.6 (10.1)	8.2 (18.1)	11.5 (25.4)			
Mounting holes [mm (in)]	a	198 (7.8)					260 (10.2)			260 (10.2)	297.5 (11.7)	390 (15.4)			
	b	60 (2.4)					70 (2.8)			90 (3.5)	105 (4.1)	120 (4.7)			
	c	5 (0.2)					6.4 (0.25)			6.5 (0.26)	8 (0.32)	7.8 (0.31)			
	d	9 (0.35)					11 (0.43)			11 (0.43)	12.4 (0.49)	12.6 (0.5)			
	e	4.5 (0.18)					5.5 (0.22)			5.5 (0.22)	6.8 (0.27)	7 (0.28)			
	f	7.3 (0.29)					8.1 (0.32)			9.2 (0.36)	11 (0.43)	11.2 (0.44)			

Table 9.7 Enclosure Sizes, Power Ratings, and Dimensions

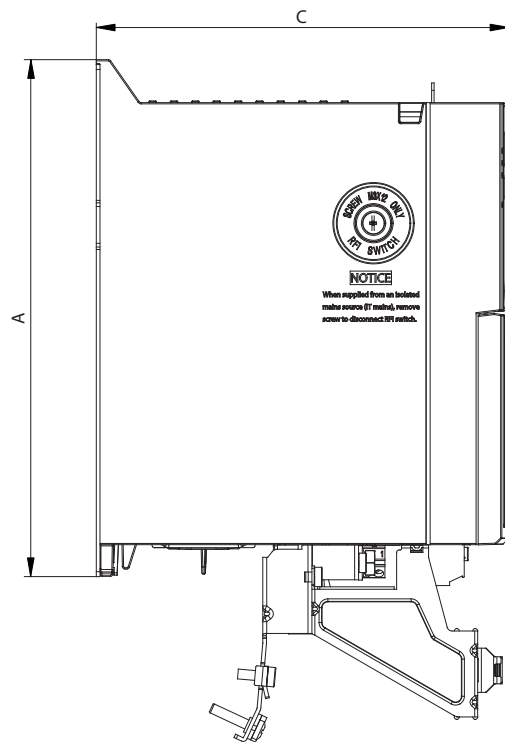
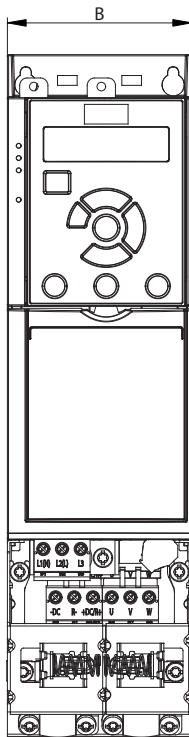

130BE844.10

Illustration 9.2 Standard with Decoupling Plate

9

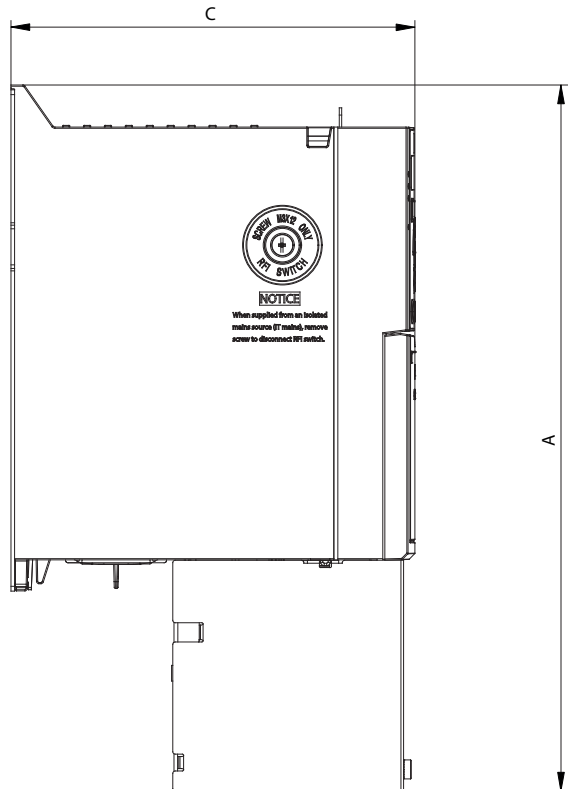
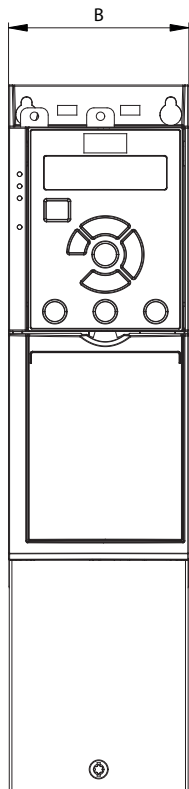

130BE846.10

Illustration 9.3 Standard with IP21

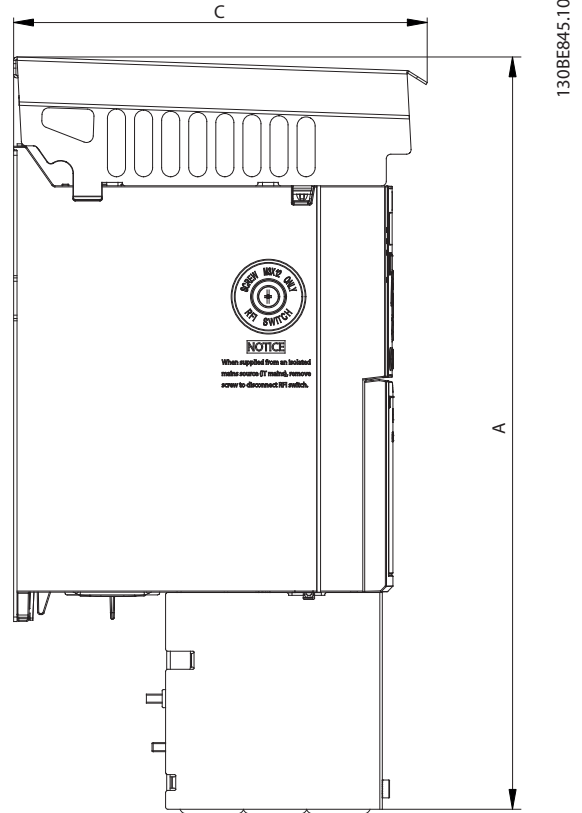
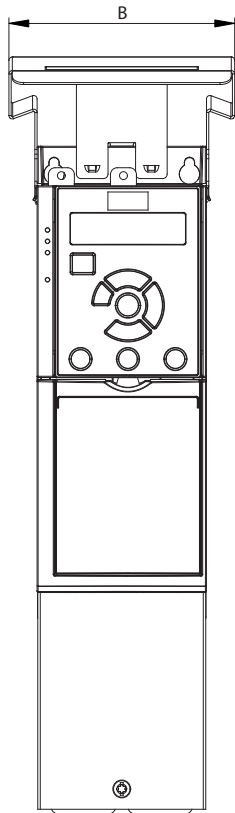

9

Illustration 9.4 Standard with NEMA/Type 1

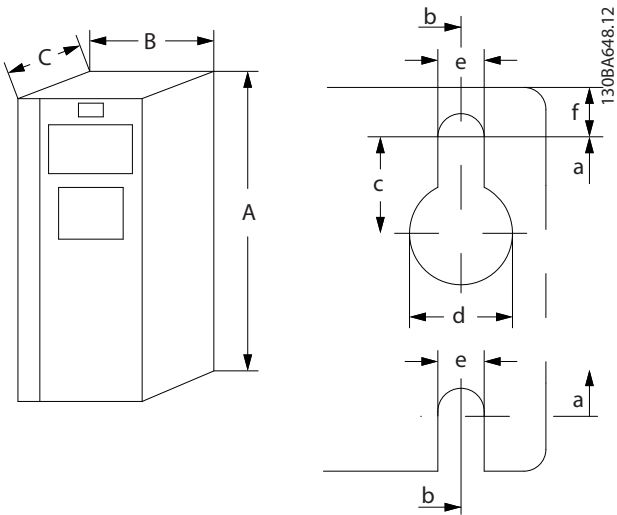

Illustration 9.5 Top and Bottom Mounting Holes

10 Appendix

10.1 Symbols, Abbreviations, and Conventions

°C	Degrees celsius
°F	Degrees fahrenheit
AC	Alternating current
AEO	Automatic energy optimization
AWG	American wire gauge
AMA	Automatic motor adaptation
DC	Direct current
EMC	Electromagnetic compatibility
ETR	Electronic thermal relay
$f_{M,N}$	Nominal motor frequency
FC	Frequency converter
I_{INV}	Rated inverter output current
I_{LIM}	Current limit
$I_{M,N}$	Nominal motor current
$I_{VLT,MAX}$	Maximum output current
$I_{VLT,N}$	Rated output current supplied by the frequency converter
IP	Ingress protection
LCP	Local control panel
MCT	Motion control tool
n_s	Synchronous motor speed
$P_{M,N}$	Nominal motor power
PELV	Protective extra low voltage
PCB	Printed circuit board
PM Motor	Permanent magnet motor
PWM	Pulse width modulation
RPM	Revolutions per minute
STO	Safe Torque Off
T_{LIM}	Torque limit
$U_{M,N}$	Nominal motor voltage

Table 10.1 Symbols and Abbreviations

Conventions

- For illustrations, all dimensions are in [mm (in)].
- An asterisk (*) indicates the default setting of a parameter.
- Numbered lists indicate procedures.
- Bullet lists indicate other information.
- Italicized text indicates:
 - Cross-reference.
 - Link.
 - Parameter name.

10.2 Parameter Menu Structure

0-0*	Operation / Display	1-33	Stator Leakage Reactance (X1)	2-14	Brake voltage reduce	4-2*	Limit Factors	5-90	Digital & Relay Bus Control
0-0*	Basic Settings	1-35	Main Reactance (Xh)	2-16	AC Brake, Max current	4-20	Torque Limit Factor Source	5-93	Pulse Out 27 Bus Control
0-01	Language	1-37	d-axis Inductance (Ld)	2-17	Over-voltage Control	4-21	Speed Limit Factor Source	5-94	Pulse Out 27 Timeout Preset
0-03	Regional Settings	1-38	q-axis Inductance (Lq)	2-19	Over-voltage Gain	4-22	Break Away Boost	6-0*	Analog In/Out
0-04	Operating State at Power-up	1-39	Motor Poles	2-2*	Mechanical Brake	4-3*	Motor Fb Monitor	6-0*	Analog I/O Mode
0-06	GridType	1-4*	Adv. Motor Data II	2-20	Release Brake Current	4-30	Motor Feedback Loss Function	6-00	Live Zero Timeout Time
0-07	Auto DC Braking	1-40	Back EMF at 1000 RPM	2-22	Activate Brake Speed [Hz]	4-31	Motor Feedback Speed Error	6-01	Live Zero Timeout Function
0-1*	Set-up Operations	1-42	Motor Cable Length	2-23	Activate Brake Delay	4-32	Motor Feedback Loss Timeout	6-1*	Analog Input 53
0-10	Active Set-up	1-43	Motor Cable Length Feet	3-3*	Reference / Ramps	4-4*	Adj. Warnings 2	6-10	Terminal 53 Low Voltage
0-11	Programming Set-up	1-44	d-axis Inductance Sat. (LdSat)	3-0*	Reference Limits	4-40	Warning Freq. Low	6-11	Terminal 53 High Voltage
0-12	Link Setups	1-45	q-axis Inductance Sat. (LqSat)	3-00	Reference Range	4-41	Warning Freq. High	6-14	Terminal 53 Low Ref./Feedb. Value
0-14	Readout: Edit Set-ups / Channel	1-46	Position Detection Gain	3-01	Reference/Feedback Unit	4-42	Adjustable Temperature Warning	6-15	Terminal 53 High Ref./Feedb. Value
0-16	Application Selection	1-48	Current at Min Inductance for d-axis	3-02	Minimum Reference	4-5*	Adj. Warnings	6-16	Terminal 53 Filter Time Constant
0-2*	LCP Display	1-49	Current at Min Inductance for q-axis	3-03	Maximum Reference	4-50	Warning Current Low	6-18	Terminal 53 Digital Input
0-20	Display Line 1.1 Small	1-5*	Load Indep. Setting	3-04	Reference Function	4-51	Warning Current High	6-19	Terminal 53 mode
0-21	Display Line 1.2 Small	1-50	Motor Magnetisation at Zero Speed	3-1*	References	4-54	Warning Reference Low	6-2*	Analog Input 54
0-22	Display Line 1.3 Small	1-52	Min Speed Normal Magnetising [Hz]	3-10	Preset Reference	4-55	Warning Reference High	6-20	Terminal 54 Low Voltage
0-23	Display Line 2 Large	1-55	U/f Characteristic - U	3-11	Jog Speed [Hz]	4-56	Warning Feedback Low	6-21	Terminal 54 High Voltage
0-24	Display Line 3 Large	1-56	U/f Characteristic - F	3-12	Catch up/slow Down Value	4-57	Warning Feedback High	6-22	Terminal 54 Low Current
0-3*	LCP Custom Readout	1-6*	Load Depen. Setting	3-14	Preset Relative Reference	4-58	Missing Motor Phase Function	6-23	Terminal 54 High Current
0-30	Custom Readout Unit	1-60	Low Speed Load Compensation	3-15	Reference 1 Source	4-6*	Speed Bypass	6-24	Terminal 54 Low Ref./Feedb. Value
0-31	Custom Readout Min Value	1-61	High Speed Load Compensation	3-16	Reference 2 Source	4-61	Bypass Speed From [Hz]	6-25	Terminal 54 High Ref./Feedb. Value
0-32	Custom Readout Max Value	1-62	Slip Compensation	3-17	Reference 3 Source	4-63	Bypass Speed To [Hz]	6-26	Terminal 54 Filter Time Constant
0-37	Display Text 1	1-63	Slip Compensation Time Constant	3-18	Relative Scaling Reference Resource	5-5*	Digital In/Out	6-29	Terminal 54 mode
0-38	Display Text 2	1-64	Resonance Dampening	3-4*	Ramp 1	5-0*	Digital I/O mode	6-9*	Analog/Digital Output 42
0-39	Display Text 3	1-65	Resonance Dampening Time Constant	3-40	Ramp 1 Type	5-00	Digital Input Mode	6-90	Terminal 42 Mode
0-4*	LCP Keypad	1-66	Min. Current at Low Speed	3-41	Ramp 1 Ramp Up Time	5-01	Terminal 27 Mode	6-91	Terminal 42 Analog Output
0-40	[H and n] Key on LCP	1-7*	Start Adjustments	3-42	Ramp 1 Ramp Down Time	5-1*	Digital Inputs	6-92	Terminal 42 Digital Output
0-42	[Auto on] Key on LCP	1-70	PM Start Mode	3-5*	Ramp 2	5-10	Terminal 18 Digital Input	6-93	Terminal 42 Output Min Scale
0-44	[Off/Reset] Key on LCP	1-71	Start Delay	3-50	Ramp 2 Type	5-11	Terminal 19 Digital Input	6-94	Terminal 42 Output Max Scale
0-5*	LCP/Save	1-72	Start Function	3-51	Ramp 2 Ramp Up Time	5-12	Terminal 27 Digital Input	6-96	Terminal 42 Output Bus Control
0-50	LCP Copy	1-73	Flying Start	3-52	Ramp 2 Ramp Down Time	5-13	Terminal 29 Digital Input	6-98	Drive Type
0-51	Set-up Copy	1-75	Start Speed [Hz]	3-6*	Ramp 3	5-14	Terminal 32 Digital Input	7-0*	Controllers
0-60	Password	1-76	Start Current	3-60	Ramp 3 Type	5-15	Terminal 33 Digital Input	7-0*	Speed PID Ctrl.
0-66	Main Menu Password	1-78	Compressor Start Max Speed [Hz]	3-61	Ramp 3 Ramp up Time	5-19	Terminal 37/38 Safe Torque Off	7-00	Speed PID Feedback Source
1-0*	Load and Motor	1-79	Compressor Start Max Time to Trip	3-62	Ramp 3 Ramp down Time	5-3*	Digital Outputs	7-02	Speed PID Proportional Gain
1-0*	General Settings	1-80	Stop Adjustments	3-7*	Ramp 4	5-30	Terminal 27 Digital Output	7-03	Speed PID Integral Time
1-00	Configuration Mode	1-80	Function at Stop	3-70	Ramp 4 Type	5-34	On Delay, Digital Output	7-04	Speed PID Differentiation Time
1-01	Motor Control Principle	1-82	Min Speed for Function at Stop [Hz]	3-71	Ramp 4 Ramp up Time	5-35	Off Delay, Digital Output	7-05	Speed PID Diff. Gain Limit
1-03	Torque Characteristics	1-83	Precise Stop Function	3-72	Ramp 4 Ramp Down Time	5-4*	Relays	7-06	Speed PID Lowpass Filter Time
1-06	Clockwise Direction	1-84	Precise Stop Counter Value	3-8*	Other Ramps	5-40	Function Relay	7-07	Speed PID Feedback Gear Ratio
1-08	Motor Control Bandwidth	1-85	Precise Stop Speed Compensation Delay	3-80	Jog Ramp Time	5-41	On Delay, Relay	7-08	Speed PID Feed Forward Factor
1-1*	Motor Selection	1-85	DC Brake Gain	3-81	Quick Stop Ramp Time	5-42	Off Delay, Relay	7-1*	Torque PID Ctrl.
1-10	Motor Construction	1-88	AC Brake Gain	3-9*	Digital Pot.Meter	5-5*	Pulse Input	7-12	Torque PID Proportional Gain
1-14	Damping Gain	1-9*	Motor Temperature	3-90	Step Size	5-50	Term. 29 Low Frequency	7-13	Torque PID Integration Time
1-15	Low Speed Filter Time Const.	1-90	Motor Thermal Protection	3-92	Power Restore	5-51	Term. 29 High Frequency	7-2*	Process Ctrl. Feedb
1-16	High Speed Filter Time Const.	1-93	Thermistor Source	3-93	Maximum Limit	5-52	Term. 29 Low Ref./Feedb. Value	7-20	Process CL Feedback 1 Resource
1-17	Voltage filter time const.	2-0*	Brakes	3-94	Minimum Limit	5-53	Term. 29 High Ref./Feedb. Value	7-22	Process CL Feedback 2 Resource
1-2*	Motor Data	2-0*	DC-Brake	3-95	Ramp Delay	5-55	Term. 33 Low Frequency	7-3*	Process PID Ctrl.
1-20	Motor Power	2-00	DC Hold/Motor Preheat Current	3-96	Maximum Limit Switch Reference	5-56	Term. 33 High Frequency	7-30	Process PID Normal/ Inverse Control
1-22	Motor Voltage	2-01	DC Brake Current	4-1*	Limits / Warnings	5-57	Term. 33 Low Ref./Feedb. Value	7-31	Process PID Anti Windup
1-23	Motor Frequency	2-02	DC Braking Time	4-1*	Motor Limits	5-58	Term. 33 High Ref./Feedb. Value	7-32	Process PID Start Speed
1-24	Motor Current	2-04	DC Brake Cut In Speed	4-10	Motor Speed Direction	5-6*	Pulse Output	7-33	Process PID Proportional Gain
1-25	Motor Nominal Speed	2-06	Parking Current	4-12	Motor Speed Low Limit [Hz]	5-60	Terminal 27 Pulse Output Variable	7-34	Process PID Integral Time
1-26	Motor Cont. Rated Torque	2-07	Parking Time	4-14	Motor Speed High Limit [Hz]	5-62	24V Encoder Max Freq 27	7-35	Process PID Differentiation Time
1-29	Automatic Motor Adaption (AMA)	2-1*	Brake Energy Funct.	4-16	Torque Limit Motor Mode	5-7*	24V Encoder Input	7-36	Process PID Diff. Gain Limit
1-3*	Adv. Motor Data I	2-10	Brake Function	4-17	Torque Limit Generator Mode	5-70	Term 32/33 Pulses Per Revolution	7-38	Process PID Feed Forward Factor
1-30	Stator Resistance (Rs)	2-11	Brake Resistor (ohm)	4-18	Current Limit	5-71	Term. 32/33 Encoder Direction	7-39	On Reference Bandwidth
1-31	Rotor Resistance (Rr)	2-12	Brake Power Limit (kW)	4-19	Max Output Frequency	5-9*	Bus Controlled		

7-4*	Adv. Process PID I	8-83 Slave Error Count	12-04 DHCP Server	13-40 Logic Rule Boolean 1	15-04 Over Temp's
7-40	Process PID I-part Reset	8-84 Slave Messages Sent	12-05 Lease Expires	13-41 Logic Rule Operator 1	15-05 Over Volt's
7-41	Process PID Output Neg. Clamp	8-85 Slave Timeout Errors	12-06 Name Servers	13-42 Logic Rule Boolean 2	15-06 Reset kWh Counter
7-42	Process PID Output Pos. Clamp	8-88 Bus FeedBack	12-07 Domain Name	13-43 Logic Rule Operator 2	15-07 Reset Running Hours Counter
7-43	Process PID Gain Scale at Min. Ref.	8-90 Bus Jog 1 Speed	12-08 Host Name	13-44 Logic Rule Boolean 3	15-3* Alarm Log
7-44	Process PID Gain Scale at Max. Ref.	8-91 Bus Jog 2 Speed	12-09 Physical Address	13-5* States	15-30 Alarm Log: Error Code
7-45	Process PID Feed Fwd Resource	9-9** PROFdrive	12-1* Ethernet Link Parameters	13-51 SL Controller Event	15-31 InternalFaultReason
7-46	Process PID Feed Fwd Normal/ Inv. Ctrl.	9-00 Setpoint	12-10 Link Status	13-52 SL Controller Action	15-4* Drive Identification
7-48	PCD Feed Forward	9-07 Actual Value	12-11 Link Duration	14** Special Functions	15-40 FC Type
7-49	Process PID Output Normal/ Inv. Ctrl.	9-15 PCD Write Configuration	12-12 Auto Negotiation	14-0* Inverter Switching	15-41 Power Section
7-5*	Adv. Process PID II	9-16 PCD Read Configuration	12-13 Link Speed	14-01 Switching Frequency	15-42 Voltage
7-50	Process PID Extended PID	9-18 Node Address	12-14 Link Duplex	14-03 Overmodulation	15-43 Software Version
7-51	Process PID Feed Fwd Gain	9-19 Drive Unit System Number	12-18 Supervisor MAC	14-07 Dead Time Compensation Level	15-44 Ordered TypeCode
7-52	Process PID Feed Fwd Ramp up	9-22 Telegram Selection	12-19 Supervisor IP Addr.	14-08 Damping Gain Factor	15-45 Actual TypeCode String
7-53	Process PID Feed Fwd Ramp down	9-23 Parameters for Signals	12-2* Process Data	14-09 Dead Time Bias Current Level	15-46 Drive Ordering No
7-56	Process PID Ref. Filter Time	9-27 Parameter Edit	12-20 Control Instance	14-1* Mains On/Off	15-48 LCP Id No
7-57	Process PID Fb. Filter Time	9-28 Process Control	12-21 Process Data Config Write	14-10 Mains Failure	15-49 SW ID Control Card
7-6*	Feedback Conversion	9-44 Fault Message Counter	12-22 Process Data Config Read	14-11 Mains Voltage at Mains Fault	15-50 SW ID Power Card
7-60	Feedback 1 Conversion	9-45 Fault Code	12-28 Store Data Values	14-12 Function at Mains Imbalance	15-51 Drive Serial Number
7-62	Feedback 2 Conversion	9-47 Fault Number	12-29 Store Always	14-15 Kin. Backup Trip Recovery Level	15-52 OEM Information
8-0*	Comm. and Options	9-52 Fault Situation Counter	12-3* EtherNet/IP	14-2* Reset Functions	15-53 Power Card Serial Number
8-0*	General Settings	9-53 Profibus Warning Word	12-30 Warning Parameter	14-20 Reset Mode	15-57 File Version
8-01	Control Site	9-63 Actual Baud Rate	12-31 Net Reference	14-21 Automatic Restart Time	15-59 Filename
8-02	Control Source	9-64 Device Identification	12-32 Net Control	14-22 Operation Mode	15-6* Option Ident
8-03	Control Timeout Time	9-65 Profile Number	12-33 CIP Revision	14-24 Trip Delay at Current Limit	15-60 Option Mounted
8-04	Control Timeout Function	9-67 Control Word 1	12-34 CIP Product Code	14-25 Trip Delay at Torque Limit	15-61 Option SW Version
8-1*	Ctrl. Word Settings	9-68 Status Word 1	12-35 EDS Parameter	14-27 Action At Inverter Fault	15-70 Option in Slot A
8-10	Control Word Profile	9-70 ECU Set-up	12-37 COS Inhibit Timer	14-28 Production Settings	15-71 Slot A Option SW Version
8-14	Configurable Control Word CTW	9-71 Profibus Save Data Values	12-38 COS Filter	14-29 Service Code	15-9* Parameter Info
8-19	Product Code	9-72 Profibus DriveReset	12-8* Other Ethernet Services	14-3* Current Limit Ctrl.	15-92 Defined Parameters
8-3*	FC Port Settings	9-75 DO Identification	12-80 FTP Server	14-30 Current Lim Ctrl, Proportional Gain	15-97 Application Type
8-30	Protocol	9-80 Defined Parameters (1)	12-81 HTTP Server	14-31 Current Lim Ctrl, Integration Time	15-98 Drive Identification
8-31	Address	9-81 Defined Parameters (2)	12-82 SMTP Service	14-32 Current Lim Ctrl, Filter Time	15-99 Parameter Metadata
8-32	Baud Rate	9-82 Defined Parameters (3)	12-83 SNMP Agent	14-4* Energy Optimising	16** Data Readouts
8-33	Parity / Stop Bits	9-83 Defined Parameters (4)	12-84 Address Conflict Detection	14-40 VT Level	16-0* General Status
8-35	Minimum Response Delay	9-84 Defined Parameters (5)	12-89 Transparent Socket Channel Port	14-41 AEO Minimum Magnetisation	16-00 Control Word
8-36	Maximum Response Delay	9-85 Defined Parameters (6)	12-9* Advanced Ethernet Services	14-44 d-axis current optimization for IPM	16-01 Reference [Unit]
8-37	Maximum Inter-char delay	9-90 Changed Parameters (1)	12-90 Cable Diagnostic	14-5* Environment	16-02 Reference [%]
8-4*	FC MC protocol set	9-91 Changed Parameters (2)	12-91 Auto Cross Over	14-50 RFI Filter	16-03 Status Word
8-42	PCD Write Configuration	9-92 Changed Parameters (3)	12-92 IGMP Snooping	14-51 DC-Link Voltage Compensation	16-05 Main Actual Value [%]
8-43	PCD Read Configuration	9-93 Changed Parameters (4)	12-93 Cable Error Length	14-52 Fan Control	16-09 Custom Readout
8-5*	Digital/Bus	9-94 Changed Parameters (5)	12-94 Broadcast Storm Protection	14-55 Output Filter	16-1* Motor Status
8-50	Coasting Select	9-99 Profibus Revision Counter	12-96 Port Config	14-6* Auto Derate	16-10 Power [kW]
8-51	Quick Stop Select	10** CAN Fieldbus	12-98 Interface Counters	14-61 Function at Inverter Overload	16-11 Power [hp]
8-52	DC Brake Select	10-0* Common Settings	12-99 Media Counters	14-63 Min Switch Frequency	16-12 Motor Voltage
8-53	Reversing Select	10-01 Baud Rate Select	13** Smart Logic	14-64 Dead Time Compensation Zero Current Level	16-13 Frequency
8-54	Reversing Select	10-02 Node ID	13-0* SLC Settings	14-65 Speed Derate Dead Time Compensation	16-14 Motor current
8-55	Set-up Select	10-05 Readout Transmit Error Counter	13-00 SL Controller Mode	14-8* Options	16-15 Frequency [%]
8-56	Preset Reference Select	10-06 Readout Receive Error Counter	13-01 Start Event	14-89 Option Detection	16-16 Torque [Nm]
8-57	Profidrive OFF2 Select	10-3* Parameter Access	13-02 Stop Event	14-9* Fault Settings	16-18 Motor Thermal
8-58	Profidrive OFF3 Select	10-31 Store Data Values	13-03 Reset SLC	14-90 Fault Level	16-20 Motor Angle
8-7*	Protocol SW Version	10-33 Store Always	13-1* Comparators	15** Drive Information	16-22 Torque [%]
8-79	Protocol Firmware version	12** Ethernet	13-10 Comparator Operand	15-0* Operating Data	16-30 DC Link Voltage
8-8*	FC Port Diagnostics	12-0* IP Settings	13-11 Comparator Operator	15-00 Operating hours	16-33 Brake Energy /2 min
8-80	Bus Message Count	12-01 IP Address	13-12 Comparator Value	15-01 Running Hours	16-34 Heatsink Temp.
8-81	Bus Error Count	12-02 Subnet Mask	13-2* Timers	15-02 kWh Counter	16-35 Inverter Thermal
8-82	Slave Messages Rcvd	12-03 Default Gateway	13-20 SL Controller Timer	15-03 Power Up's	16-36 Inv. Nom. Current
			13-4* Logic Rules	15-03	16-37 Inv. Max. Current

16-38	SL Controller State	21-24	Ext. 1 Dif. Gain Limit	34-26	PCD 6 Read For Application
16-39	Control Card Temp.	22-** Appl. Functions		34-27	PCD 7 Read For Application
16-5* Ref. & Feedsb.		22-0* Miscellaneous		34-28	PCD 8 Read For Application
16-50	External Reference	22-02	Sleepmode CL Control Mode	34-29	PCD 9 Read For Application
16-52	Feedback[Unit]	22-4* Sleep Mode		34-30	PCD 10 Read For Application
16-53	Digi. Pot Reference	22-40	Minimum Run Time	34-5* Process Data	
16-57	Feedback [RPM]	22-41	Minimum Sleep Time	34-50	Actual Position
16-6* Inputs & Outputs		22-43	Wake-Up Speed [Hz]	34-56	Track Error
16-60	Digital Input	22-44	Wake-Up Ref./FB Diff	37-** Application Settings	
16-61	Terminal 53 Setting	22-45	Setpoint Boost	37-0* ApplicationMode	
16-62	Analog input 53	22-46	Maximum Boost Time	37-00	Application Mode
16-63	Terminal 54 Setting	22-47	Sleep Speed [Hz]	37-1* Position Control	
16-64	Analog Input 54	22-48	Sleep Delay Time	37-01	Pos. Feedback Source
16-65	Analog output 42 [mA]	22-49	Wake-Up Delay Time	37-02	Pos. Target
16-66	Digital Output	22-6* Broken Belt Detection		37-03	Pos. Type
16-67	Pulse Input 29[Hz]	22-60	Broken Belt Function	37-04	Pos. Velocity
16-68	Pulse Input 33 [Hz]	22-61	Broken Belt Torque	37-05	Pos. Ramp Up Time
16-69	Pulse Output 27 [Hz]	22-62	Broken Belt Delay	37-06	Pos. Ramp Down Time
16-71	Relay output	30-** Special Features		37-07	Pos. Auto Brake Ctrl
16-72	Counter A	30-2* Adv. Start Adjust		37-08	Pos. Hold Delay
16-73	Counter B	30-20	High Starting Torque Time [s]	37-09	Pos. Coast Delay
16-74	Prec. Stop Counter	30-21	High Starting Torque Current [%]	37-10	Pos. Brake Delay
16-8* Fieldbus & FC Port		30-22	Locked Rotor Protection	37-11	Pos. Brake Wear Limit
16-80	Fieldbus CTW 1	30-23	Locked Rotor Detection Time [s]	37-12	Pos. PID Anti Windup
16-82	Fieldbus REF 1	32-** Motion Control Basic Settings		37-13	Pos. PID Output Clamp
16-84	Comm. Option STW	32-12	User Unit Numerator	37-14	Pos. Ctrl. Source
16-85	FC Port CTW 1	32-67	Max. Tolerated Position Error	37-15	Pos. Direction Block
16-86	FC Port REF 1	32-80	Maximum Allowed Velocity	37-17	Pos. Ctrl Fault Behaviour
16-9* Diagnosis Readouts		32-81	Motion Ctrl Quick Stop Ramp	37-18	Pos. Ctrl Fault Reason
16-90	Alarm Word	33-** Homing Mode		37-19	Pos. New Index
16-91	Alarm Word 2	33-00	Homing Mode		
16-92	Warning Word	33-01	Home Offset		
16-93	Warning Word 2	33-02	Home Ramp Time		
16-94	Ext. Status Word	33-03	Homing Velocity		
16-95	Ext. Status Word 2	33-04	Homing Behaviour		
16-97	Alarm Word 3	33-41	Negative Software Limit		
18-** Data Readouts 2		33-42	Positive Software Limit		
18-9* PID Readouts		33-43	Negative Software Limit Active		
18-90	Process PID Error	33-44	Positive Software Limit Active		
18-91	Process PID Output	33-47	Target Position Window		
18-92	Process PID Clamped Output	34-** Motion Control Data Readouts			
18-93	Process PID Gain Scaled Output	34-0* PCD Write Par.			
21-** Ext. Closed Loop		34-01	PCD 1 Write For Application		
21-0* Ext. CL Autotuning		34-02	PCD 2 Write For Application		
21-09	Extended PID Enable	34-03	PCD 3 Write For Application		
21-1* Ext. CL 1 Ref./Fb.		34-04	PCD 4 Write For Application		
21-11	Ext. 1 Minimum Reference	34-05	PCD 5 Write For Application		
21-12	Ext. 1 Maximum Reference	34-06	PCD 6 Write For Application		
21-13	Ext. 1 Reference Source	34-07	PCD 7 Write For Application		
21-14	Ext. 1 Feedback Source	34-08	PCD 8 Write For Application		
21-15	Ext. 1 Setpoint	34-09	PCD 9 Write For Application		
21-17	Ext. 1 Reference [Unit]	34-10	PCD 10 Write For Application		
21-18	Ext. 1 Feedback [Unit]	34-2* PCD Read Par.			
21-19	Ext. 1 Output [%]	34-21	PCD 1 Read For Application		
21-2* Ext. CL 1 PID		34-22	PCD 2 Read For Application		
21-20	Ext. 1 Normal/Inverse Control	34-23	PCD 3 Read For Application		
21-21	Ext. 1 Proportional Gain	34-24	PCD 4 Read For Application		
21-22	Ext. 1 Integral Time	34-25	PCD 5 Read For Application		
21-23	Ext. 1 Differentiation Time				

Index

A

Abbreviation.....	61
AC input.....	5, 17
AC mains.....	5, 17
AC waveform.....	5
Additional resource.....	4
Alarm log.....	28
AMA with T27 connected.....	39
Ambient condition.....	52
Approval and certification.....	5
Auto on.....	28, 33
Auxiliary equipment.....	21

B

Backplate.....	10
Branch circuit protection.....	56
Burst transient.....	13

C

Cable length.....	53
Cable routing.....	21
Cable size.....	16
Circuit breaker.....	21
Clearance requirement.....	10
Conduct.....	21
Control	
Characteristic.....	56
terminal.....	28, 46
Wiring.....	12, 19, 21

Control card	
+10 V DC output.....	55
Performance.....	55
RS485 serial communication.....	55
USB serial communication.....	55

Convention.....	61
Cooling.....	10
Cooling clearance.....	21
Cross-section.....	53
Customer relay.....	37

D

DC current.....	5
Default setting.....	29
Derating.....	52
Digital input.....	19
Discharge time.....	7

Disconnect switch.....	22
Disposal instruction.....	6

E

EMC.....	52
EMC-compliant installation.....	12
Encoder rotation.....	32
Energy efficiency.....	50, 51
Energy efficiency class.....	52
External command.....	5
External controller.....	4

F

Fault	
log.....	28
Feedback.....	21
Floating delta.....	17
Fuse.....	12, 21, 56

G

Ground connection.....	21
Ground wire.....	12
Grounded delta.....	17
Grounding.....	16, 17, 21, 22

H

Hand on.....	28
High voltage.....	7, 22

I

IEC 61800-3.....	17, 52
------------------	--------

Initialization	
Manual procedure.....	30
Procedure.....	30

Input

Current.....	17
power wiring.....	21
voltage.....	22
Power.....	5, 12, 17, 21, 22
Terminal.....	17, 22

Inputs

Analog input.....	54
Digital input.....	53
Pulse input.....	54

Installation.....	21
-------------------	----

Installation environment.....	10
-------------------------------	----

Intended use.....	4
-------------------	---

Interference isolation.....	21
-----------------------------	----

Isolated main.....	17
--------------------	----

J	
Jumper.....	19
L	
Leakage current.....	8, 12
Lifting.....	10
Load sharing.....	7
Local control.....	28
M	
Main menu.....	26, 28
Mains	
Supply (L1/N, L2/L, L3).....	52
Supply data.....	50
Voltage.....	28
Maintenance.....	42
Mechanical brake control.....	19
Menu key.....	23, 28
Menu structure.....	28
Motor	
Current.....	5, 31
Data.....	30, 32
cable.....	12, 16
current.....	28
output.....	52
power.....	28
thermal protection.....	5
Power.....	12
Protection.....	4
Rotation.....	32
Status.....	4
Mounting.....	10, 21
N	
Nameplate.....	9
Navigation key.....	23, 28
Numeric display.....	23
O	
Open loop.....	56
Operation key.....	23, 28
Optional equipment.....	22
Output current.....	54
Output power wiring.....	21
Outputs	
Analog output.....	55
Digital output.....	54
Overcurrent protection.....	12
P	
PELV.....	41, 55
Potential equalization.....	13
Power connection.....	12
Power factor.....	5, 21
Programming.....	19, 28, 29
Q	
Qualified personnel.....	7
Quick menu.....	24, 28
R	
Recycling.....	6
Reference.....	28
Relay output.....	55
Remote command.....	4
Reset.....	28, 30, 42
RFI filter.....	17
Run command.....	33
S	
Safety.....	8
Serial communication.....	20, 28, 42, 55
Service.....	42
Set-up.....	33
Shielded cable.....	21
Shock.....	10
Side-by-side installation.....	10
SIL2.....	6
SILCL of SIL2.....	6
Specification.....	21
Speed reference.....	33, 39
Standard and compliance for STO.....	6
Start-up.....	30
STO	
Activation.....	36
Automatic restart.....	36, 37
Commissioning test.....	36
Deactivation.....	36
Maintenance.....	37
Manual restart.....	36, 37
Technical data.....	38
Storage.....	9
Supply voltage.....	22, 55
Symbol.....	61
System feedback.....	4

T

Terminal tightening torque..... 56

Terminals

Control terminal..... 28, 46

Output terminal..... 22

Thermal protection..... 5

Thermistor..... 41

Torque

characteristic..... 52

Transient protection..... 5

U

Unintended start..... 7, 42

V

Vibration..... 10

Voltage level..... 53

W

Warning and alarm list..... 46

Wire size..... 12



.....
Danfoss can accept no responsibility for possible errors in catalogues, brochures and other printed material. Danfoss reserves the right to alter its products without notice. This also applies to products already on order provided that such alterations can be made without subsequential changes being necessary in specifications already agreed. All trademarks in this material are property of the respective companies. Danfoss and the Danfoss logotype are trademarks of Danfoss A/S. All rights reserved.
.....

Danfoss A/S
Ulsnaes 1
DK-6300 Graasten
vlt-drives.danfoss.com

